

User Manual



All-in-one solar charge inverter

ASP48160SH3 | ASP48180SH3 | ASP48200SH3

CONTENTS

1.Safety Precautions	1
1.1 How to Use This Instruction Manual	1
1.2 Safety signs	1
1.3 Safety Instructions	1
2.Product Introduction	2
2.1 Product Description	2
2.2 Product Features	2
2.3 System Connection Diagram	3
2.4 Product Overview	4
2.5 Product Size	5
3.Installation	6
3.1 Parts List	6
3.2 Mounting Instructions	7
4.Connection Instructions	9
4.1 Single-Phase or Three-Phase Mode	9
4.2 Cable & Circuit Breaker Requirement	11
4.3 GRID & LOAD & Generator Connection	12
4.4 Battery Connection	13
4.5 PV Connection	14
4.6 Dry Contact Connection	15
4.7 Grounding Connection	15
4.8 Final Installation	16
4.9 Parallel Connection	16
5.Operation	20
5.1 Operation and Display Panel	20
5.2 Setting	24
5.3 AC Output Mode	32
5.4 Battery Charging Mode	34
5.5 Time-slot Charging/Discharging Function	35
5.6 Battery Parameters	36
6.Communication	38
6.1 Product Overview	38
6.2 USB Communication Function	38
6.3 WiFi Communication Function	39
6.4 RS485/CAN Communication Function	39
6.5 Dry Contact Function	40
6.6 DRM(Only Australia)	41
6.7 Parallel Communication Function	41
6.8 External CT Connection(Customer Optional)	41
7.Fault Codes and Countermeasures	43
7.1 Fault Codes	43
7.2 Troubleshooting	45
8.Protection and Maintenance	46
8.1 Protection Functions	46
8.2 Maintenance	47
9.Datasheet	48

1. Safety Precautions





1.1 How to Use This Instruction Manual

This manual contains important information, guidelines, operation and maintenance for the following products :

ASP Series 48160SH3, 48180SH3, and 48200SH3.

Read the manual and other related documents before performing any operation on the inverter. Documents must be stored carefully and be available at all times.

1.2 Safety signs

 DANGER	DANGER: Indicates a hazardous situation which, if not avoided, will result in death or serious injury.
 WARNING	WARNING: Indicates a hazardous situation which, if not avoided, could result in death or serious injury.
 CAUTION	CAUTION: Indicates a hazardous situation which, if not avoided, may result in minor or moderate injury.
 NOTICE	NOTICE: Provides tips or cues regarding product operation.

1.3 Safety Instructions

WARNING: This chapter contains important safety and operating instructions. Read and keep this manual for future reference.

- Be sure to comply the local requirements and regulation to install this inverter.
- Beware of high voltage. Please turn off the switch of each power sources before and during the installation to avoid electric shock.
- For optimum operation of this inverter, please follow required specification to select appropriate cable size and necessary protective device.
- Do not connect or disconnect any connections when the inverter is working.
- Do not open the terminal cover when the inverter working.
- Make sure the inverter is well grounding.
- Never cause AC output and DC input short circuited.
- Do not disassembly this unit, for all repair and maintenance, please take it to the professional service center.
- Never charge a frozen battery.
- Please keep children away from touching or mishandling the inverter.
- Please make sure that this inverter is the only input power source for the load, do not use it in parallel with other input AC power sources to avoid damage. Ensure this inverter is the sole input power source for the load. Do not parallel it with other AC input power sources to avoid damage.

2. Product Introduction

2.1 Product Description

The ASP SH3 series is a new type of solar energy storage inverter integrating solar energy storage, utility power charging storage, and AC sine wave output. Adopting DSP control and advanced control algorithms, it features fast response speed, high reliability, and compliance with industrial standards.

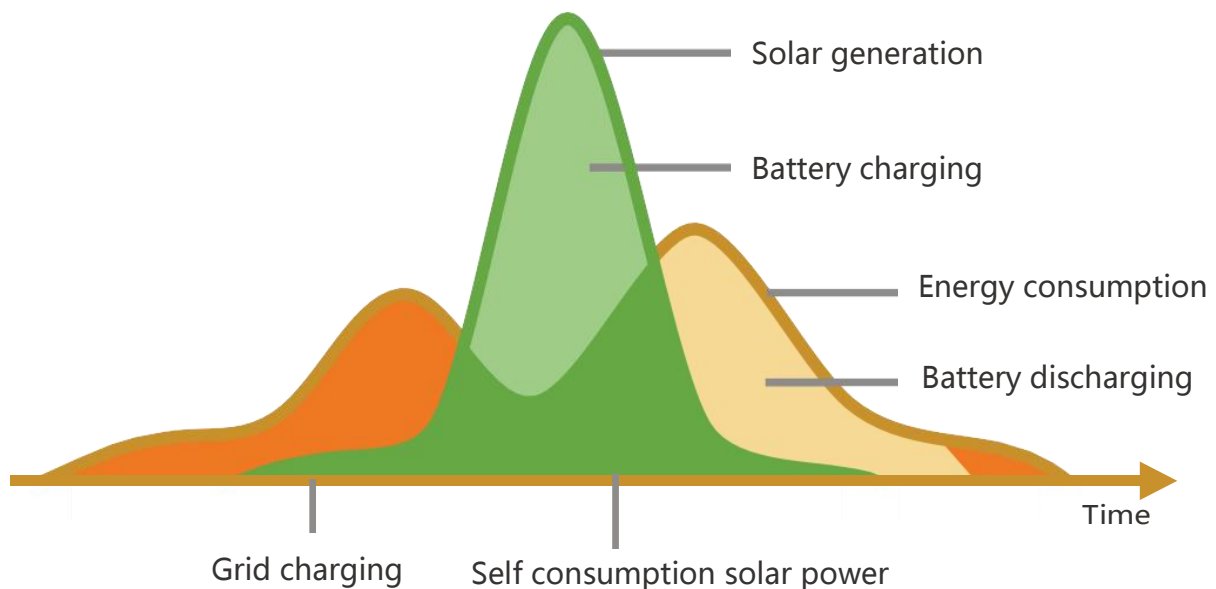

2.2 Product Features

- Supports connection of lead-acid batteries and lithium-ion batteries.
- Features Dual activation function when lithium-ion batteries are in hibernation; activation of lithium-ion batteries can be triggered by either mains power or photovoltaic power input.
- Supports three-phase pure sine wave output (350~415V).
- Supports phase voltage adjustment within the AC range of 200, 208, 220, 230 and 240 volts.
- Supports two-way photovoltaic input, with the function of simultaneously tracking the maximum power charging or load-carrying capacity of two MPPTs.
- Dual MPPT with 99.9% efficiency and maximum 36A current in a single circuit, perfectly adapted to high power modules.
- 2 charging modes are available: solar only, mixed mains/PV charging.
- With the time-slot charging and discharging setting function, you can set the time period for cutting in/out of mains charging and switch the time period between battery discharging and mains bypass power supply mode.
- Energy saving mode function to reduce no-load energy losses.

- With two output modes of utility bypass and inverter output, with uninterrupted power supply function.
- LCD large screen dynamic flow diagram design, easy to understand the system data and operation status.
- 360° protection with complete short circuit protection, over current protection, over under voltage protection, overload protection, backfill protection, etc.
- Support CAN, USB, and RS485 communication.

2.3 System Connection Diagram

The diagram below shows the system application scenario of this product. A complete system consists of the following components:

- **PV modules:** Converts light energy into DC energy, which can be used to charge the battery via an inverter or directly inverted into AC power to supply the load.
- **Utility grid or generator:** Connected to the AC input, it can supply the load and charge the battery at the same time. The system can also operate generally without the mains or generator when the battery and the PV module power the load.
- **Battery:** The role of the battery is to ensure the regular power supply of the system load when the solar energy is insufficient and there is no mains power.
- **Home load:** Various household and office loads can be connected, including refrigerators, lamps, televisions, fans, air conditioners, and other AC loads.
- **Inverter:** The energy conversion device of the whole system.

Note: The actual application scenario determines the specific system wiring method.

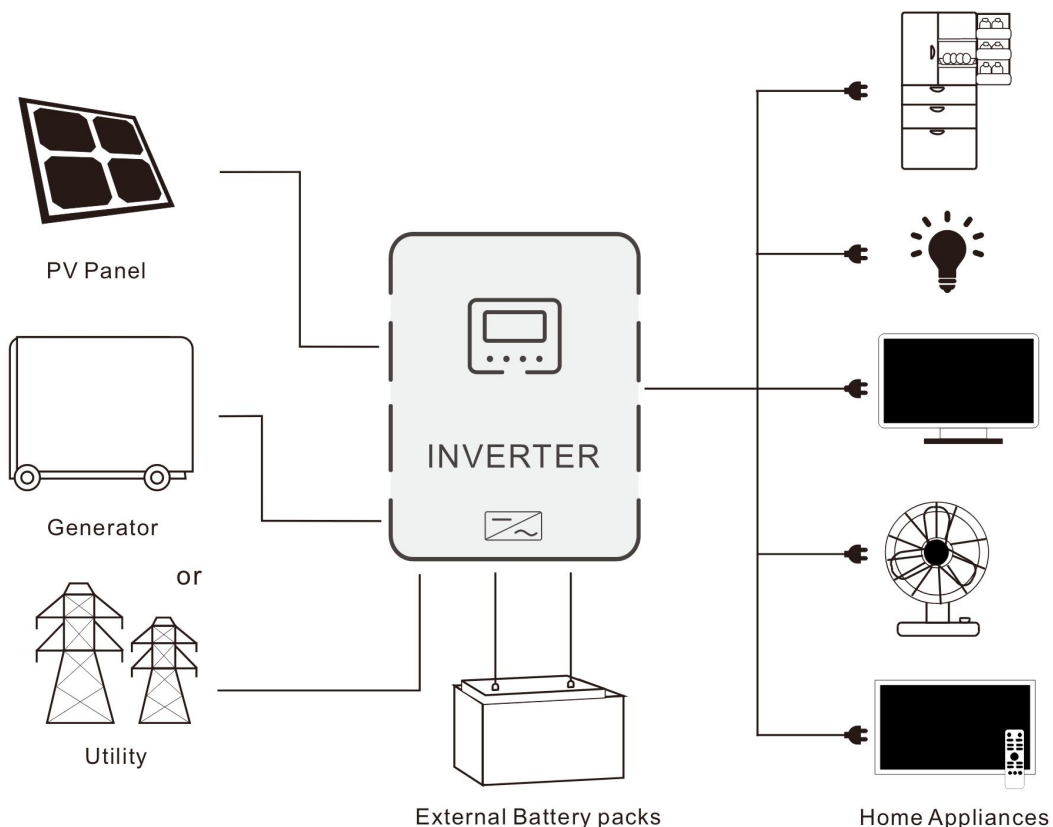

2.4 Product Overview

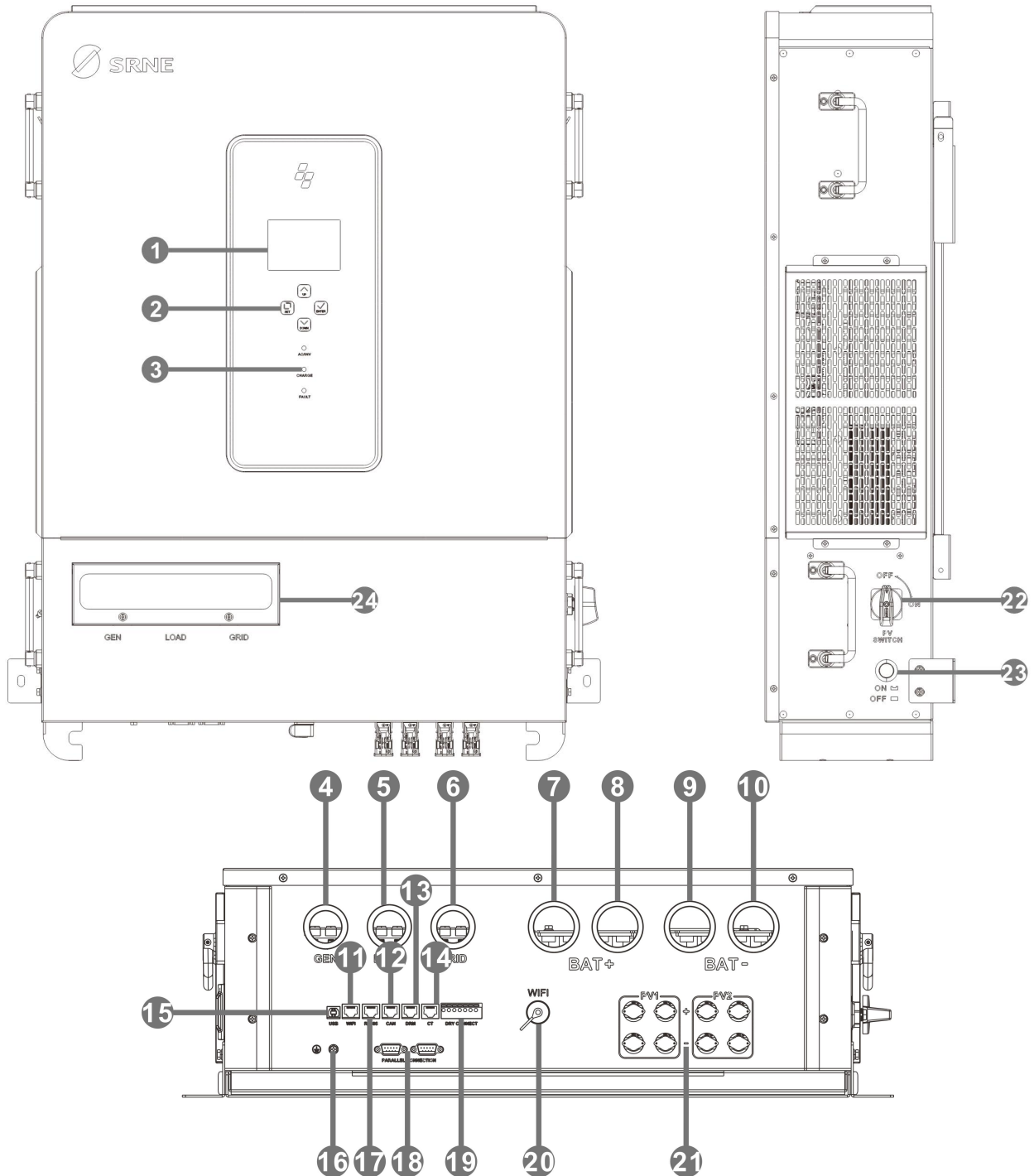

1	LED Indicators	2	LCD Screen	3	LCD Physical Buttons
4	Generator Input (L1 + L2 + L3 + N)	5	AC Output (L1 + L2 + L3 + N)	6	Grid Input (L1 + L2 + L3 + N)
7	Battery +	8	Battery +	9	Battery -
10	Battery -	11	WiFi Port	12	CAN Port
13	DRM Port	14	CT Port	15	USB Port
16	Grounding Screw	17	RS485 Port	18	Parallel Port
19	Dry Contact Prot	20	WIFI Port	21	PV Input (PV1 + PV2)
22	PV Switch	23	Power on/off switch	24	GEN/LOAD/GRID Circuit Breaker



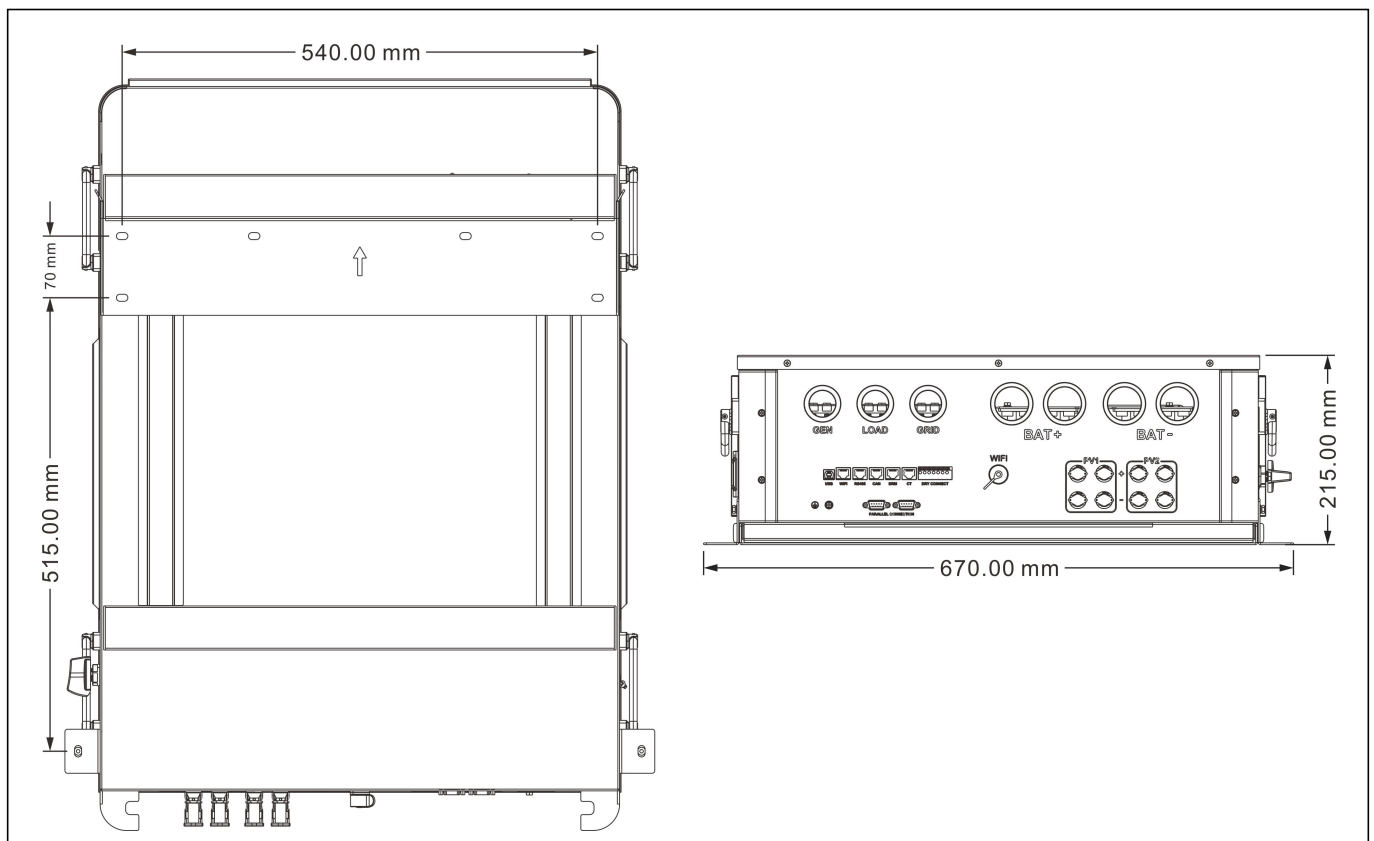
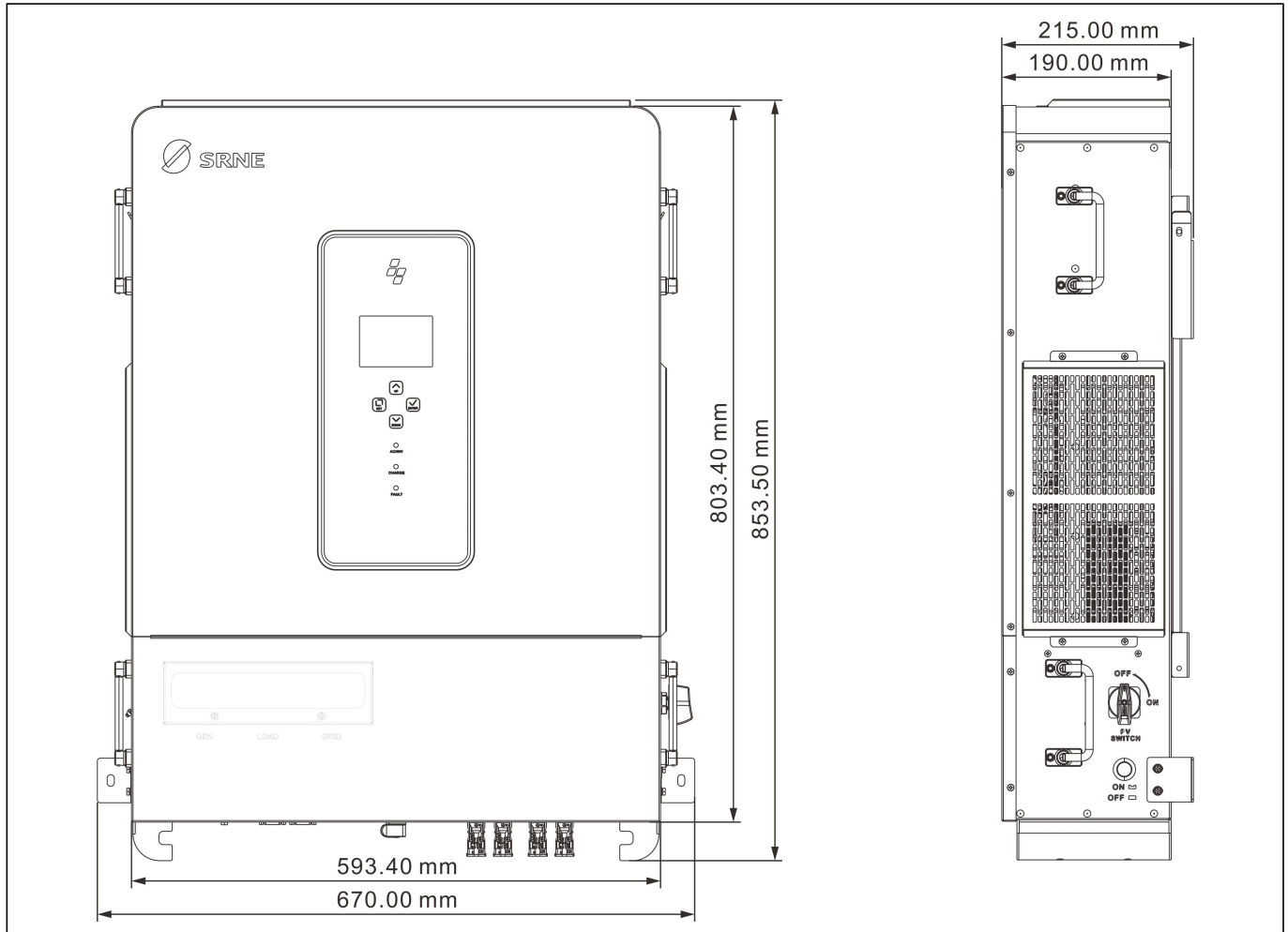







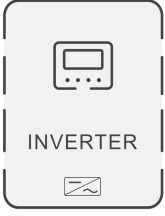

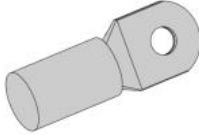

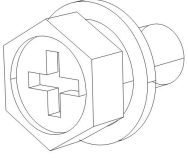
2.5 Product Size

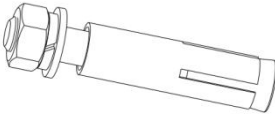
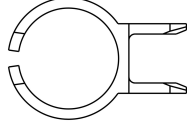
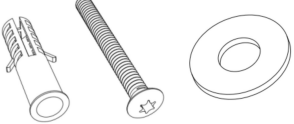

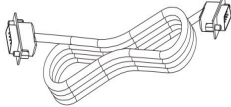
3. Installation

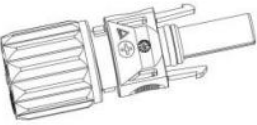
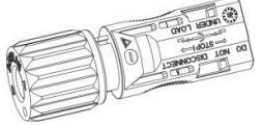
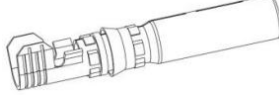
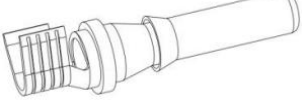
3.1 Parts List

Please check the equipment before installation. Make sure that there is no damage to the packaging. You should have received the following items in the package:

 <p>Inverter x 1pcs</p>	 <p>Wall mount bracket x 1pcs</p>	 <p>Crimp Terminal SC95-8 x 4pcs</p>	 <p>Crimp Terminal SC50-8 x 8pcs</p>
 <p>Hexagon socket cross recessed screw M8x12mm x 9pcs</p>	 <p>Hexagon socket cross recessed screw M5x10mm x 4pcs</p>	 <p>Expansion bolt M8*60mm x 4pcs</p>	 <p>MC4 unlocking tool x 1pcs</p>
 <p>Round-head self- tapping screws FA6x35 + white rubber plugs + washers x 1bag</p>	 <p>WiFi logger x 1pcs</p>	 <p>Parallel cable x 1pcs</p>	 <p>Black screw M4x8mm x 4pcs</p>
 <p>PV+ terminal x 4pcs</p>	 <p>PV- terminal x 4pcs</p>	 <p>PV+ Input Metal Core x 4pcs</p>	 <p>PV- Input Metal Core x 4pcs</p>
 <p>User Manual x 1pcs</p>	 <p>The warranty card x 1pcs</p>	 <p>Quality Certificate x 1pcs</p>	 <p>Outgoing inspection report x 1pcs</p>

3.2 Mounting Instructions

3.2.1 Installation Location Selection

ASP SH3 Series is designed for indoor use only (IP20 rated). Consider the following factors when selecting the installation location:

- Choose the solid wall to install the inverter.
- Mount the inverter at eye level.
- Adequate heat dissipation space must be provided for the inverter.
- The ambient temperature should be between $-10 \sim 55^{\circ}\text{C}$ ($14 \sim 131^{\circ}\text{F}$) to ensure optimal operation.

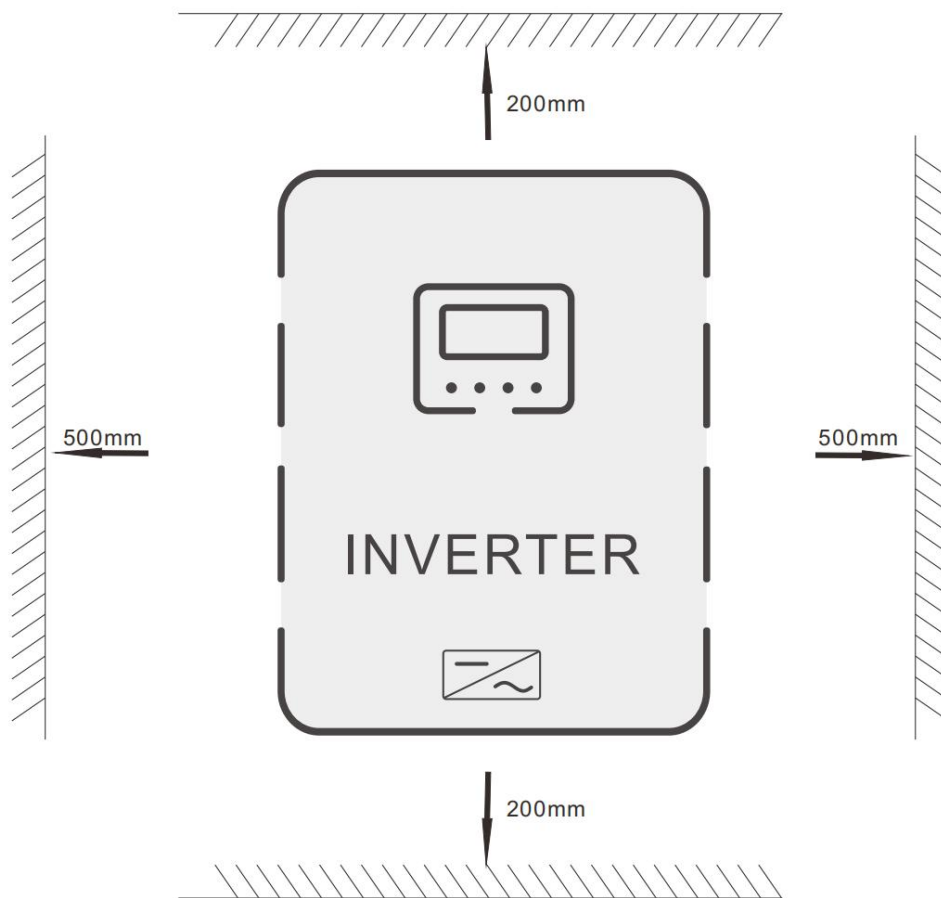

DANGER

- Do not install the inverter where highly flammable materials are near by.
- Do not install the inverter in potential explosive areas.
- Do not install the inverter with lead-acid batteries in a confined space.

CAUTION

- Do not install the inverter in direct sunlight.
- Do not install or use the inverter in a humid environment.

3.2.2 Mounting the Inverter

- **Step 1:** Use the wall-mounting bracket as a template to determine the drilling positions. Ensure the holes are level, mark them with a marker, and use a rotary hammer to drill into the wall. Keep the drill perpendicular to the wall to avoid shaking and prevent surface damage. If there is significant deviation in hole positioning, remeasure and reposition.
- **Step 2:** Select a solid wall with a thickness of at least 80 mm, and drill four holes according to the marked positions (hole diameter: $\varnothing 8$, depth: 45–50 mm). Insert M8 expansion bolts into the holes and tighten the nuts securely.
- **Step 3:** Align the wall-mounting bracket with the drilled holes, and fasten it firmly to the wall by tightening the expansion bolts and nuts.
- **Step 4:** ① Install the inverter. Slowly hang the inverter on the frame via the matching hooks, then tighten the screws on both sides. ② Mark the positions of the bent feet on both sides according to the hole positions. Remove the bent feet and drill two holes with a diameter of $\varnothing 6$ and a depth of 35–40 mm. Then install the bent feet and tighten them with M6 self-tapping screws.

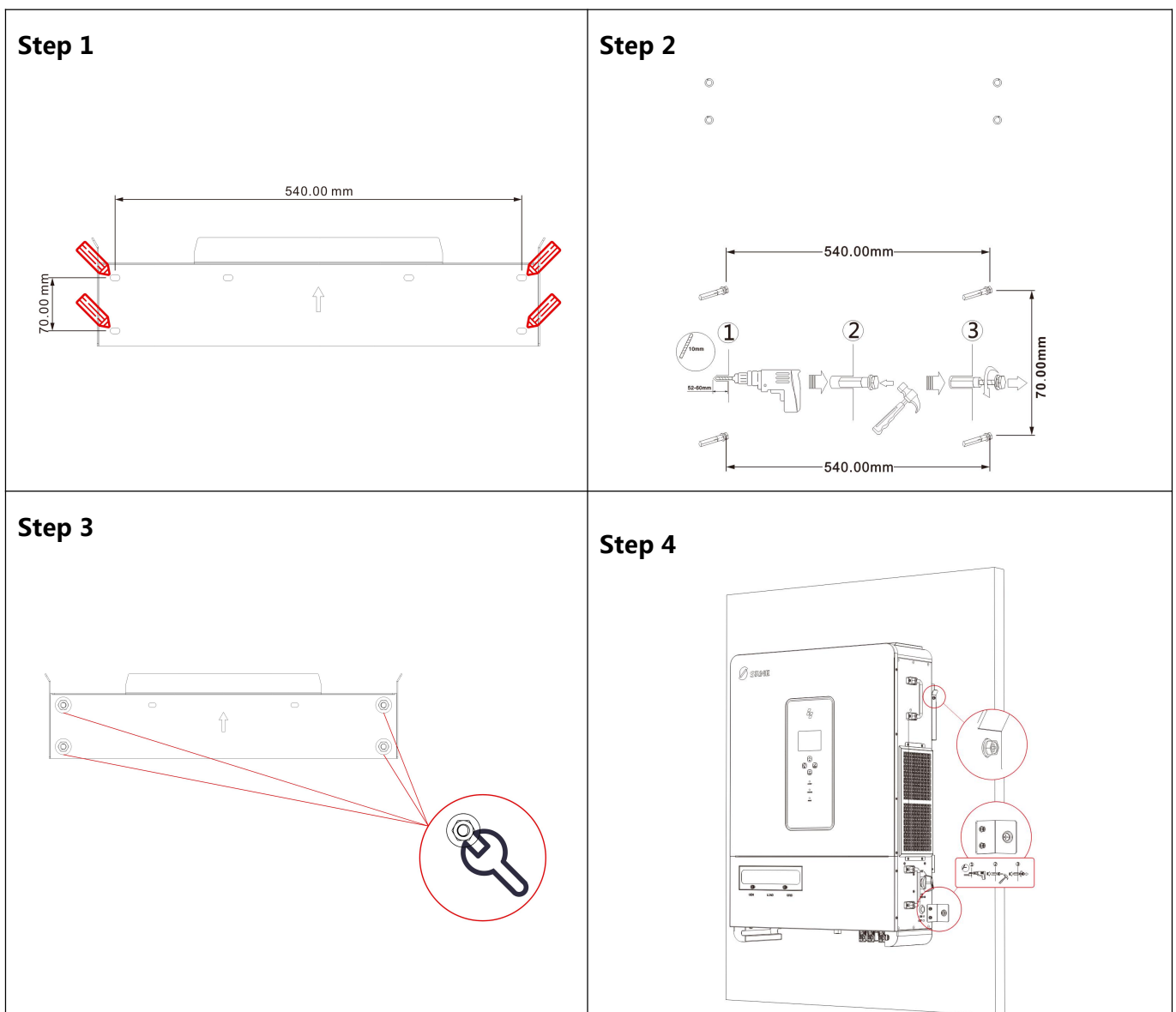

3.2.3 Removing the Terminal Protection Cover

Using a screwdriver, remove the terminal protection cover and anti-insect net.

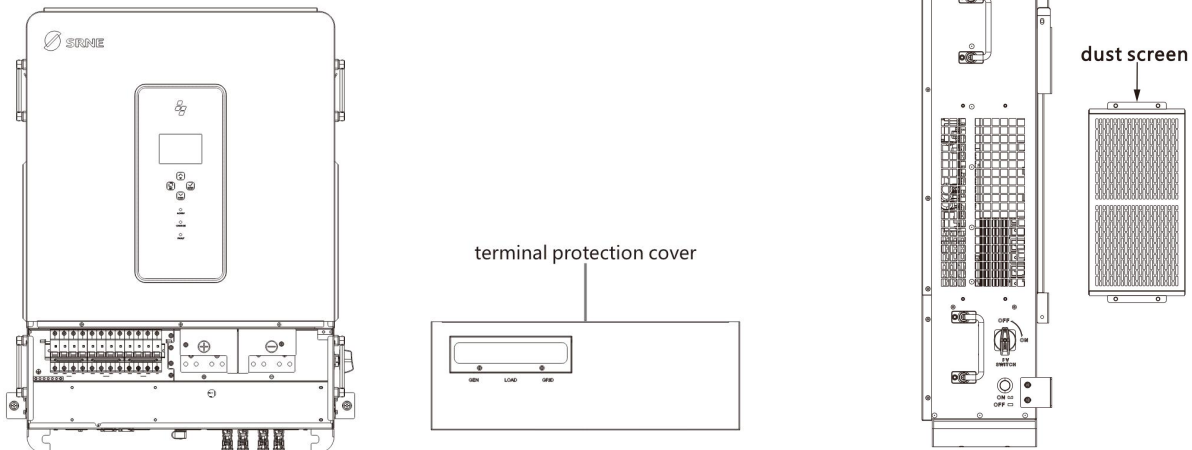

NOTICE

When using the device in areas with poor air quality, the dust screen is prone to being blocked by air particles. Please regularly remove and clean the dust screen to avoid affecting the internal air circulation rate of the frequency converter, which may cause over-temperature protection faults (Fault 19/20) and affect the service life of the power supply and inverter.

4. Connection Instructions

4.1 Single-Phase or Three-Phase Mode

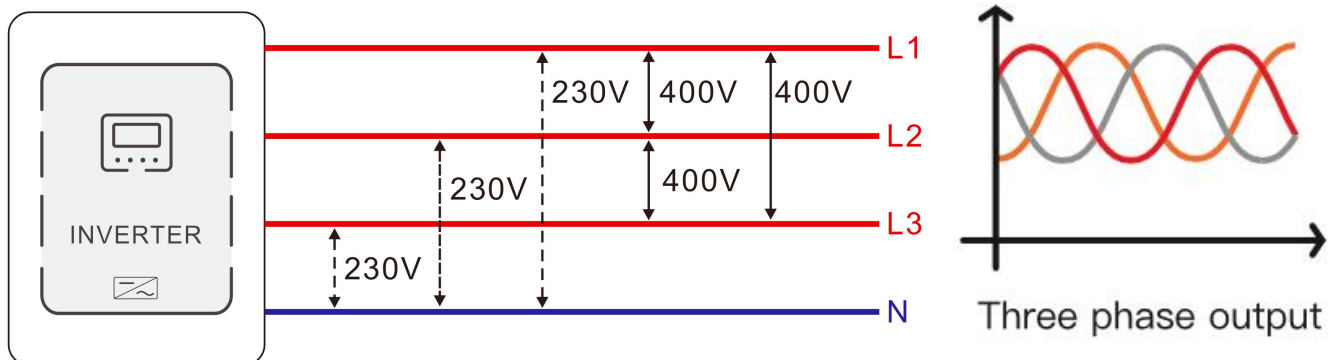

Project	Description
Applicable model	ASP series SH3 model
AC output phase voltage (L-N)	200~240Vac, 230Vac default

NOTICE

- Users can change the output phase mode and output voltage through the settings menu. For details, please refer to Chapter 5.2.
- The output voltage corresponds to parameter setting item [38], and the output phase voltage can be set within the range of 200V to 240V.

Three-phase Mode

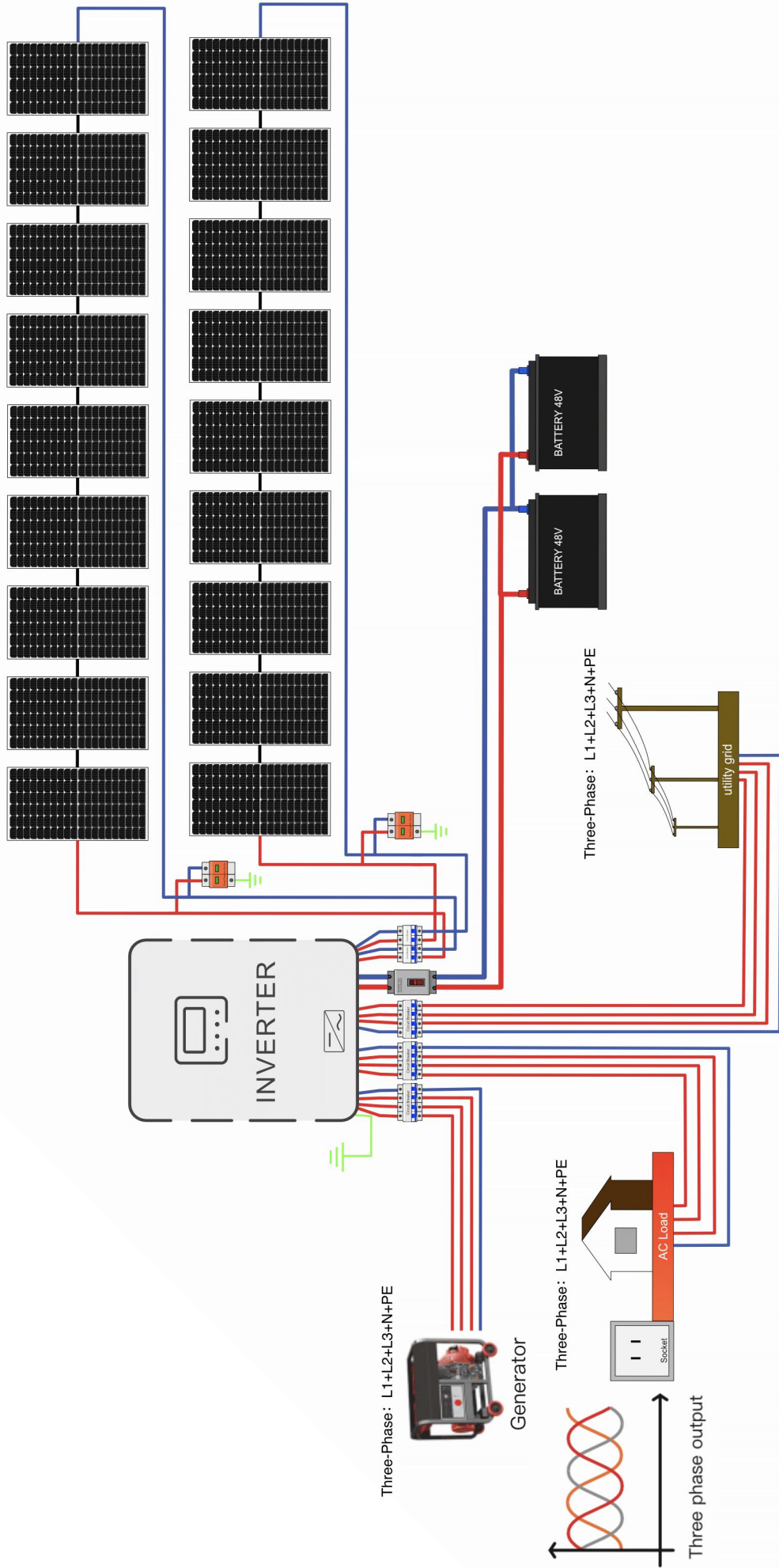

4.2 Cable & Circuit Breaker Requirement

■ PV Input

Models	Cable Diameter	Max. Input Current	Circuit Breaker Specifications
ASP48160SH3	6mm ² / 10AWG	36A	2P-45A
ASP48180SH3	6mm ² / 10 AWG	36A	2P-45A
ASP48200SH3	6mm ² / 10AWG	36A	2P-45A

■ Battery

Models	Cable Diameter	Max. Input Current	Circuit Breaker Specifications
ASP48160SH3	Mode 1: 70 mm ² /00 AWG*2 Mode 2: 30 mm ² /2 AWG*4	300A	2P-350A
ASP48180SH3	Mode 1: 85 mm ² / 000 AWG*2 Mode 2: 40mm ³ /1 AWG*4	360A	2P-400A
ASP48200SH3	Mode 1: 85 mm ² / 000 AWG*2 Mode 2: 40mm ² /1 AWG*4	360A	2P-400A

■ Grid

Models	Output Mode	Cable Diameter	Max. Input Current	Circuit Breaker Specifications
ASP48160SH3	Three-phase	15mm ² /6 AWG (L1/L2/L3/N)	60A	4P-65A
ASP48180SH3	Three-phase	15mm ² /6 AWG (L1/L2/L3/N)	60A	4P-65A
ASP48200SH3	Three-phase	15mm ² /6 AWG (L1/L2/L3/N)	60A	4P-65A

■ Generator

Models	Output Mode	Cable Diameter	Max. Input Current	Circuit Breaker Specifications
ASP48160SH3	Three-phase	15mm ² /6 AWG (L1/L2/L3/N)	60A	4P-65A
ASP48180SH3	Three-phase	15mm ² /6 AWG (L1/L2/L3/N)	60A	4P-65A
ASP48200SH3	Three-phase	15mm ² /6 AWG (L1/L2/L3/N)	60A	4P-65A

■ Load

Models	Output Mode	Cable Diameter	Max. Output Current	Circuit Breaker Specifications
ASP48160SH3	Three-phase	15mm ² /6 AWG (L1/L2/L3/N)	21.8A	4P-65A
ASP48180SH3	Three-phase	15mm ² /6 AWG (L1/L2/L3/N)	26.1A	4P-65A
ASP48200SH3	Three-phase	15mm ² /6 AWG (L1/L2/L3/N)	29.0A	4P-65A

● AC input, and AC output:

1. Use a stripper to remove the 6~8mm insulation of the cable.
2. Fixing a ferrule at the end of the cable. (ferrule needs to be prepared by the user)

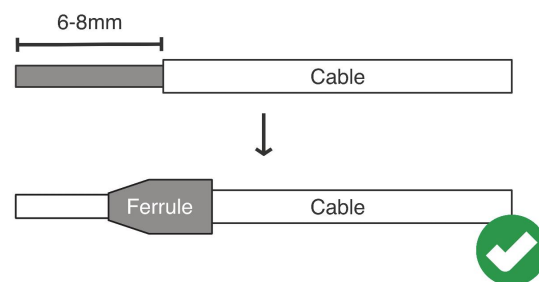
● Battery connections:

1. Use a stripper to remove the 6~8mm insulation of the cable
2. Fixing cable lugs that supply with the box at the end of the cable.

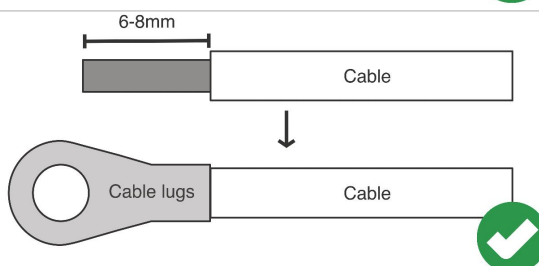

The wire diameter is for reference only. If the distance between the PV array and the inverter or between the inverter and the battery is long, using a thicker wire will reduce the voltage drop and improve the performance of the system.

4.3 GRID & LOAD & Generator Connection

Connect the live, neutral and ground wires according to the cables' position and order shown in the diagram below.

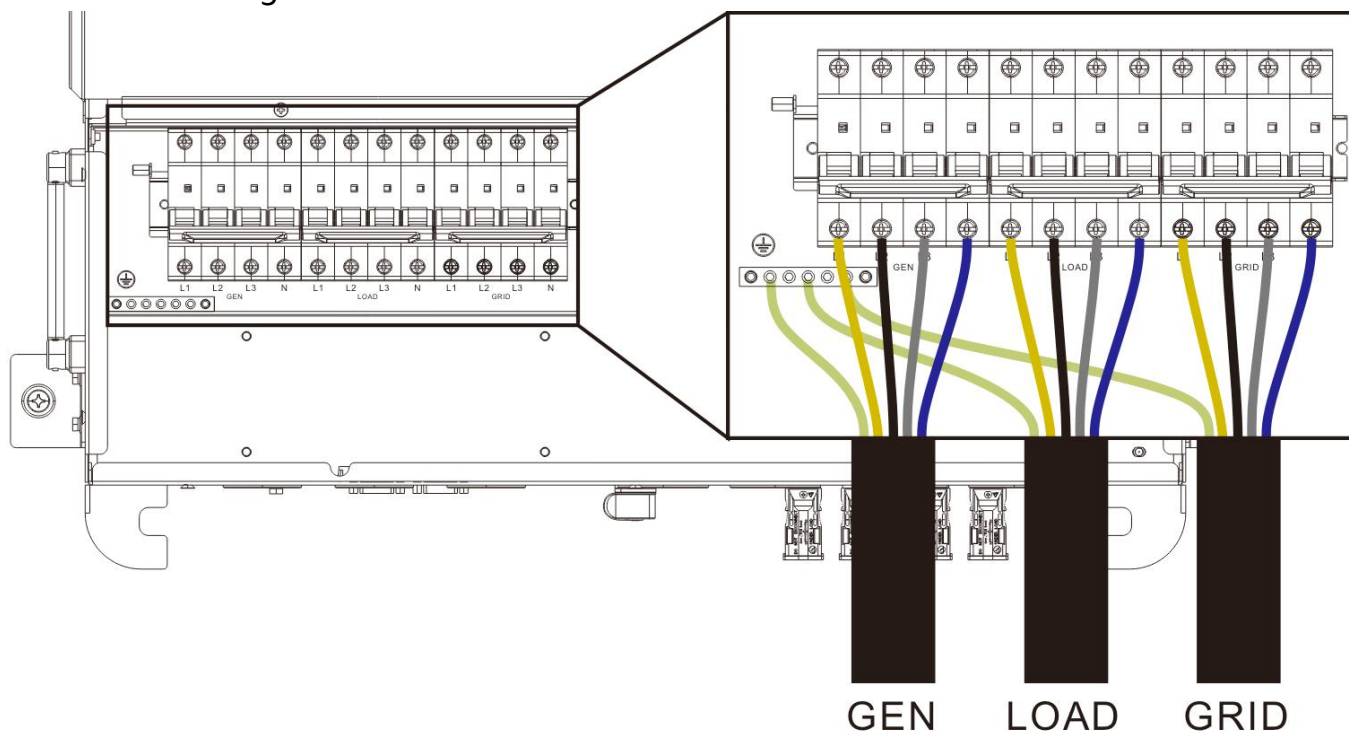

- Before connecting AC input and output, the circuit breaker must be turned off to avoid electric shock hazards, and never operate with electricity.
- Please check that the cable used is sufficient for the requirements, too thin, poor quality cables are a serious safety hazard.

4.4 Battery Connection

Connect the positive and negative cable of the battery according to the diagram below.

- Mode 1:** Each cable is recommended to be 85 mm² / 000 AWG, using crimp terminals SC95-8.

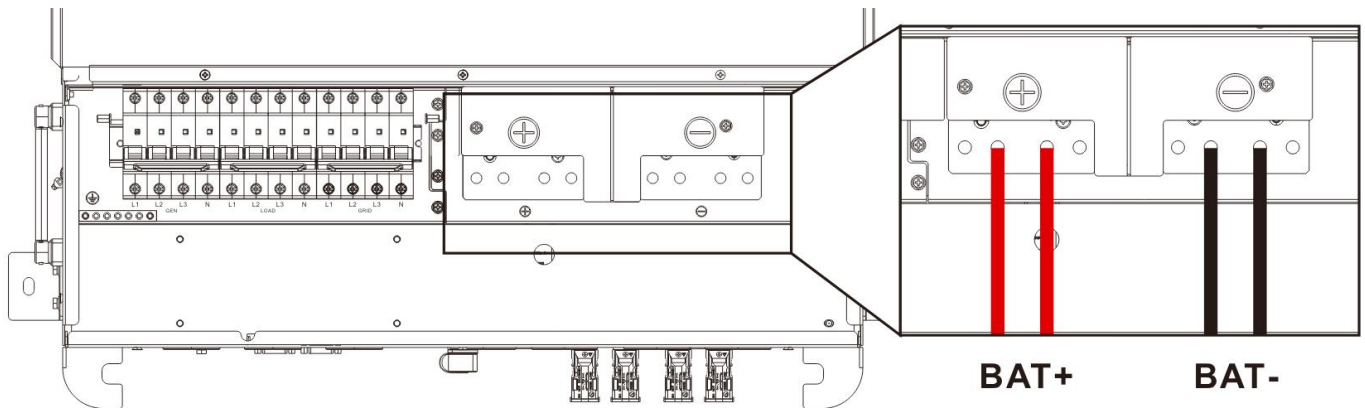

- Mode 2:** Each cable is recommended to be 40 mm²/1 AWG, using crimp terminals SC50-8.

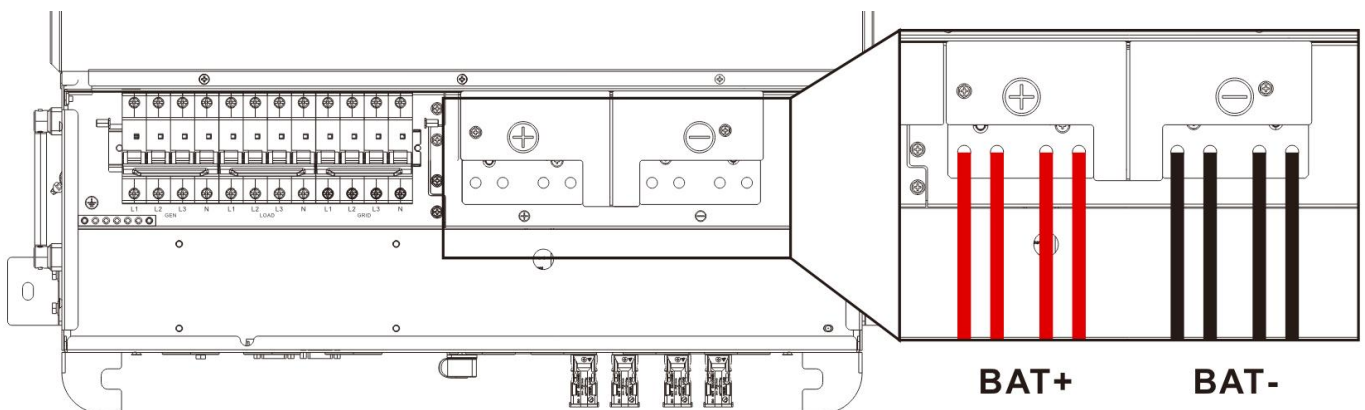

DANGER

- Before connecting battery, the circuit breaker must be turned off to avoid electric shock hazards, and never operate with electricity.
- Make sure that the positive and negative terminals of the battery are connected correctly, reversed polarity connection on battery will damage the inverter.
- Please check that the cable used is sufficient for the requirements, too thin, poor quality cables are a serious safety hazard.

4.5 PV Connection

1. Before connecting PV, first close the external circuit breaker and make sure that the cable used is sufficiently thick. Please refer to section "4.2 Cable & Circuit Breaker Selection".

2. According to the cable sequence and terminal positions shown in the figure below, correctly connect the PV input wires. When using in parallel, different units must be connected to different PV arrays or PV sources.

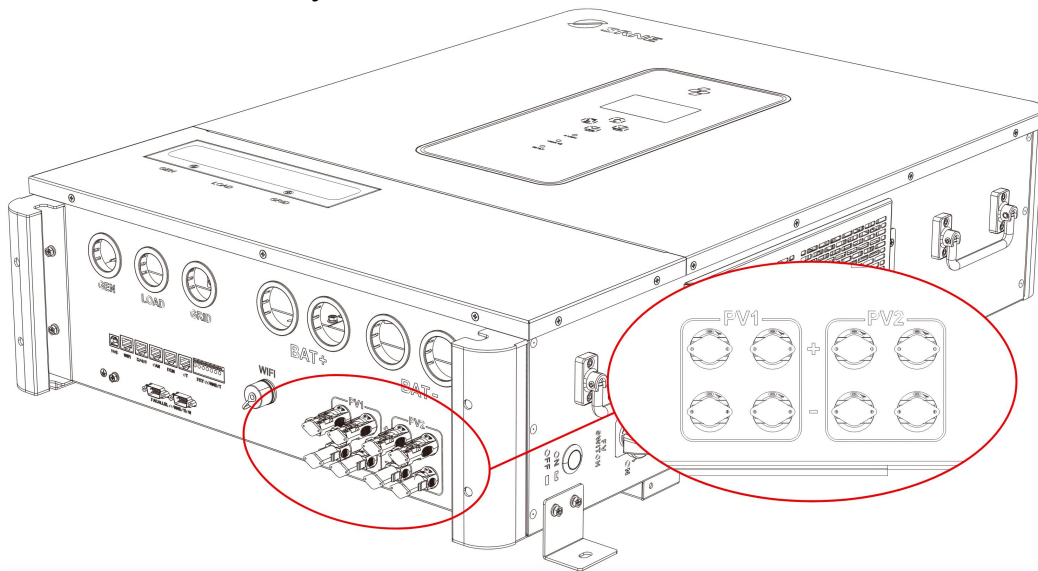

<p>① PV+ metal contact ② PV- metal contact</p>	<p>Press the wire by crimping tool</p>	<p>③ Positive connector ④ Negative connector Hear "click"</p>
<p>Tighten terminal</p>	<p>Connect to the inverter port</p>	<p>Disconnect PV terminal</p>

DANGER

- Before connecting the PV, the circuit breaker must be turned off to avoid electric shock hazards, and never operate with electricity.
- Make sure that the open-circuit voltage of the PV modules connected in series does not exceed the maximum open-circuit voltage of the inverter (the value is 1000V), otherwise the inverter may be damaged.

Transmitter-PLC Device(Customer Optional)

The APsmart Rapid Shutdown System Transmitter-PLC is part of a rapid shutdown solution when paired with APsmart RSD-D, a PV module rapid shutdown unit. While powered on, the Transmitter-PLC sends a signal to the RSD-D units to keep their PV modules connected and supplying energy. RSD-D units automatically enter rapid shutdown mode when the Transmitter-PLC is switched off and resume energy production when power is restored to the Transmitter-PLC

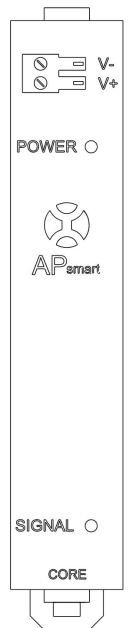

4.6 Dry Contact Connection

Use a small screwdriver to push back the direction indicated by the arrow, then insert the communication cable into the dry junction port.
(Communication cable diameter 0.2~1.5mm²)

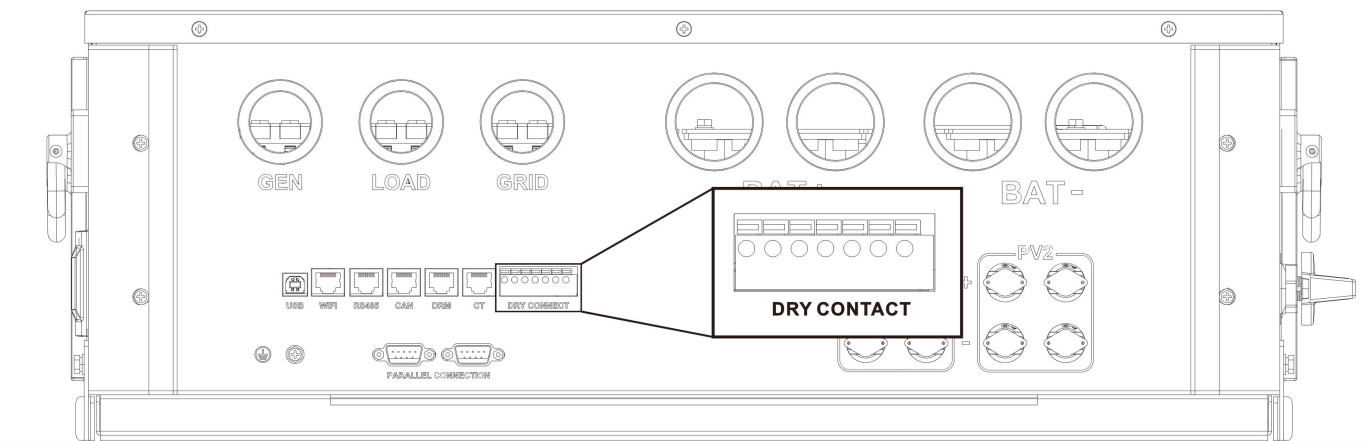

4.7 Grounding Connection

Please make sure the grounding terminal connect to the Grounding Bar.

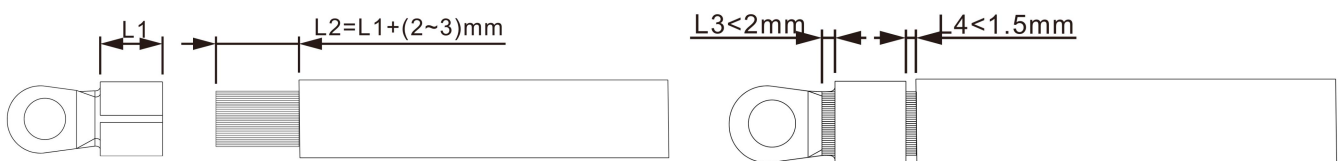

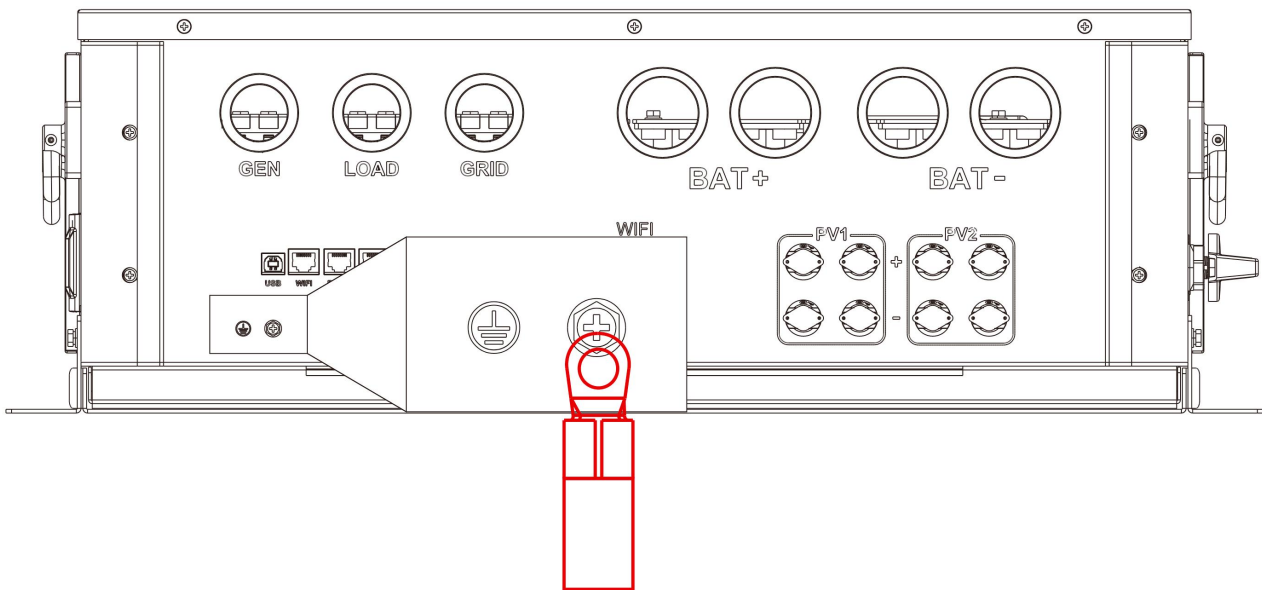

NOTICE

Grounding wire shall be not less than 4 mm² in diameter and as close as possible to the earthing point.

4.8 Final Installation

After ensuring that the wiring is reliable and the wire sequence is correct, install the terminal protection cover in place.

- **Step 1:** Close the circuit breaker of the battery.
- **Step 2:** Press the ON/OFF switch on the side of the inverter. The screen and indicator lights turning on indicates that the inverter has been activated.
- **Step 3:** Sequential close of the circuit breakers for PV, AC input and AC output.
- **Step 4:** Start the loads one by one in order of power from small to large.

4.9 Parallel Connection

4.9.1 Introduction to Parallel Connection

1. Up to six units connected in parallel.
2. When using the parallel operation function, the following connecting lines (package accessories) shall be firmly and reliably connected.

Parallel communication cable *1

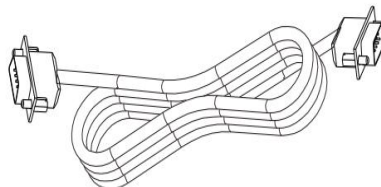

4.9.2 Precautions for Connecting the Parallel Connecting Lines

Warning

1.PV connection:

When connecting in parallel, the PV arrays connected to each inverter must be independent of each other. The PV arrays corresponding to PV1, PV2 ports of the same inverter must also be independent.

2.Battery connection:

When paralleling, all solar energy storage inverters must be connected to the same battery, with BAT+ connected to BAT+ and BAT- connected to BAT-. Before powering on and starting, it is necessary to check and ensure that the connections, wiring length, and cable size are correct to prevent abnormal operation of the parallel system output caused by incorrect connections.

3.Load connection:

For three-phase parallel connection: all solar storage inverters must be connected in the manner of N-to-N and PE-to-PE. The L lines of all inverters in the same phase shall be connected together, but the AC output L lines of different phases shall not be connected together. Other cautions are the same as those for single-phase parallel connection. Refer to the schematic diagram for wiring.

4.Grid connection:

In three-phase parallel connection, all solar storage inverters must be connected in the manner of N-to-N and PE-to-PE. The L lines of all inverters in the same phase shall be connected together, but the AC output L lines of different phases shall not be connected together. Refer to the schematic diagram for wiring.

5.Communication Lines:

The parallel-operation communication cables produced by our company are DB15 standard computer cables with shielding function, designed for parallel-machine connection. Each inverter should adopt an "one-out-one-in" connection mode: the male connector (output) of an inverter must be connected to the female connector (input) of the parallel inverter. In addition, the communication cable of each parallel inverter will be secured with DB15 terminal screws to prevent the communication cable from falling off or poor contact, which may otherwise cause abnormal operation or damage to the system output.

6. Before and after connecting the system, carefully refer to the system wiring diagram below. Ensure all connections are correct and secure before powering on.

7. After the system is correctly wired, powered on, and operating normally, if a new inverter needs to be connected, ensure that the battery input, PV input, AC input, and AC output are disconnected, and all solar energy storage inverters are powered off before reconnecting to the system.

4.9.3 Schematic Diagram of Parallel Connection

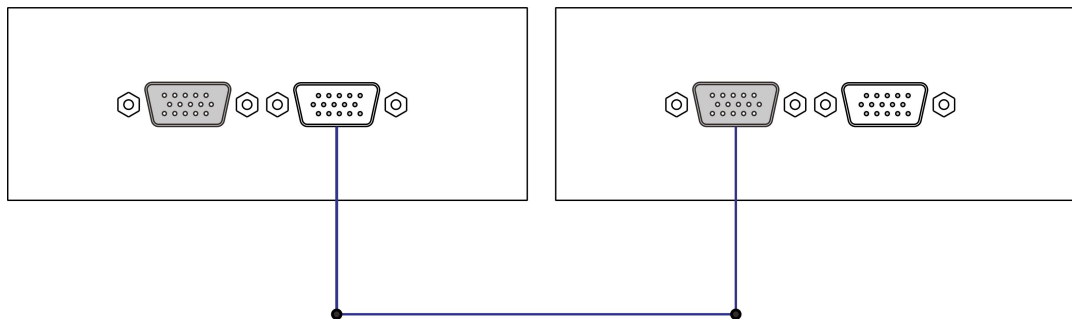
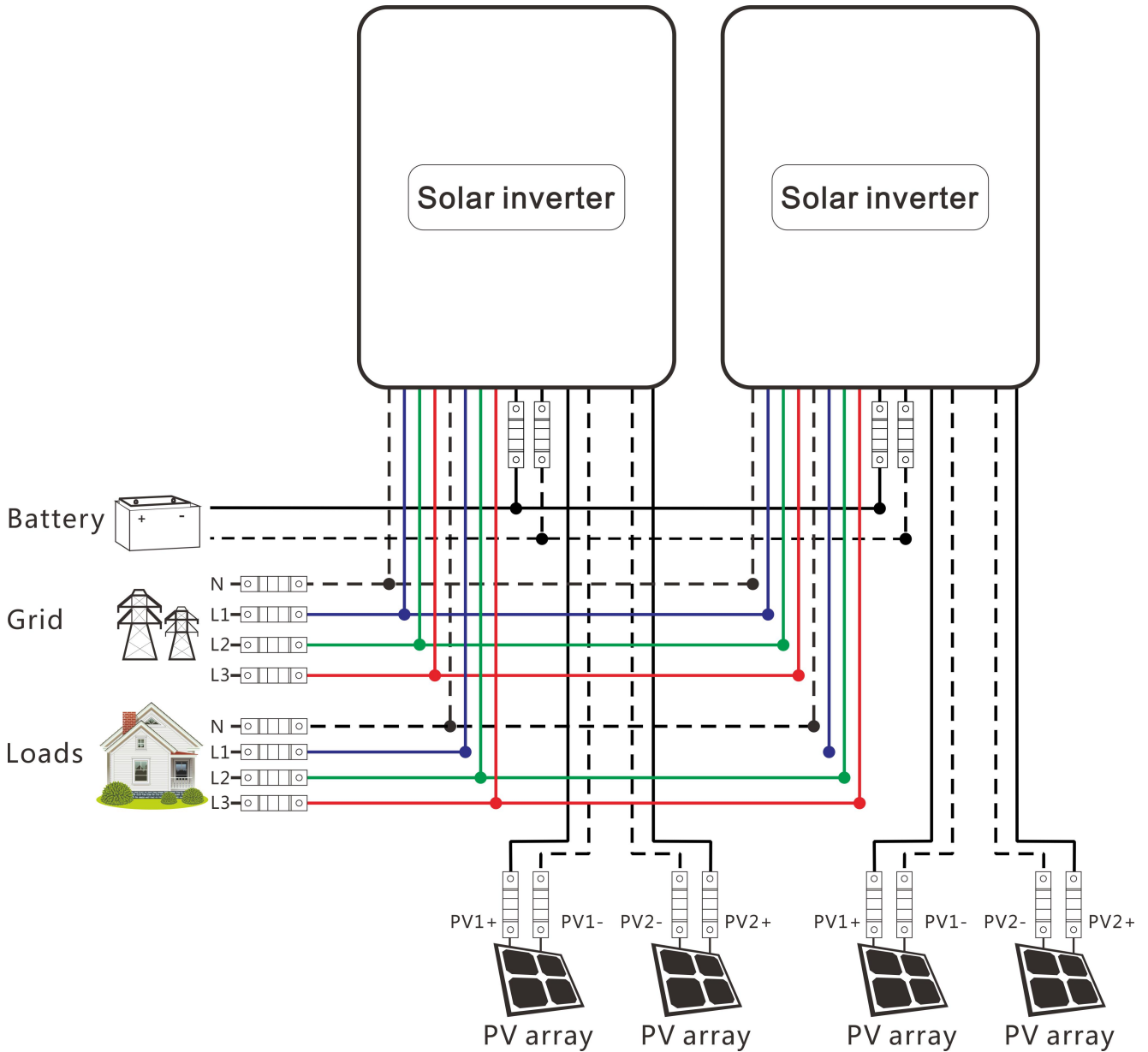

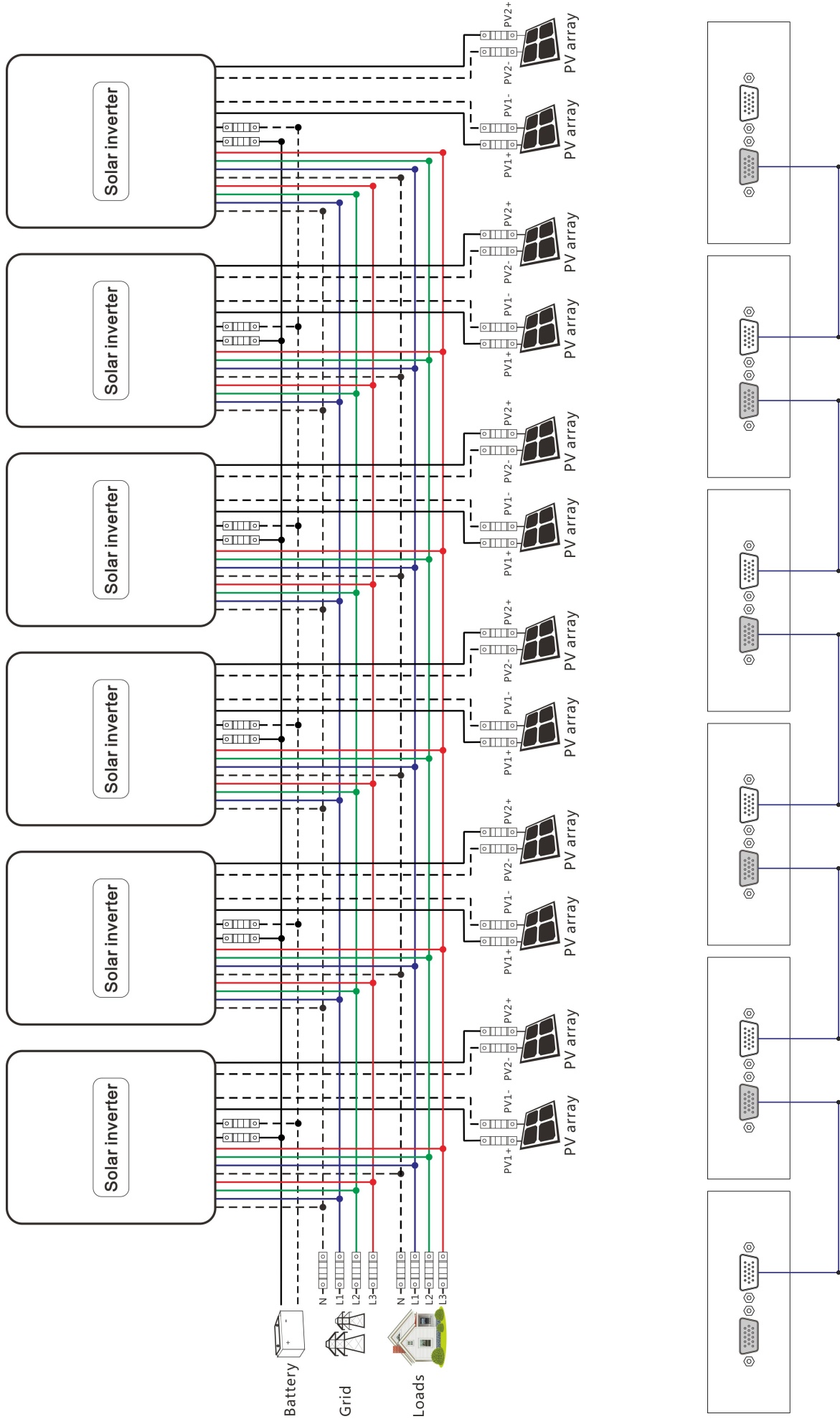



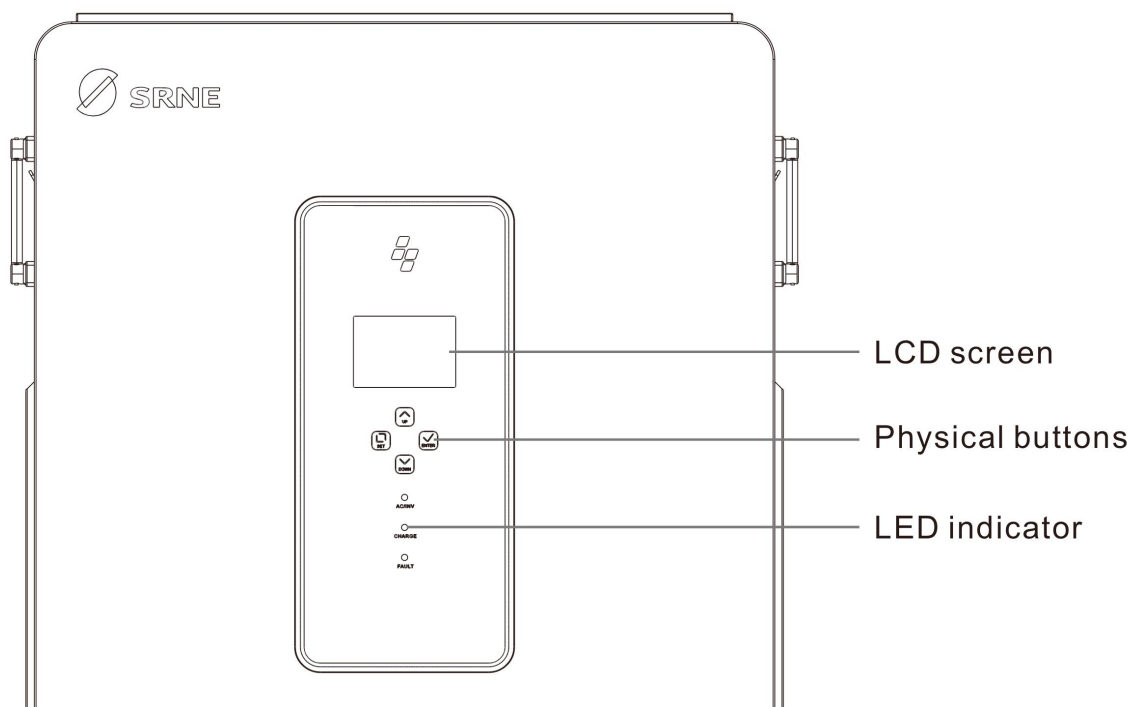

5. Operation

5.1 Operation and Display Panel

The operation and display panel below includes 1 LCD screen, 3 LED indicators, and 4 physical buttons.



■ Physical buttons

Button	Description
	To enter/exit settings menu
	To go to previous selection
	To go to next selection
	To confirm/enter selection in settings menu

■ LED indicators

Indicator	Color	Description
AC/INV	Green	Steady on: Mains bypass output
		Flashing: Inverter output
CHARGE	Yellow	Steady on: Charging completed
		Flashing: Charging in progress
FAULT	Red	Flashing: Fault occurred

■ Display Panel

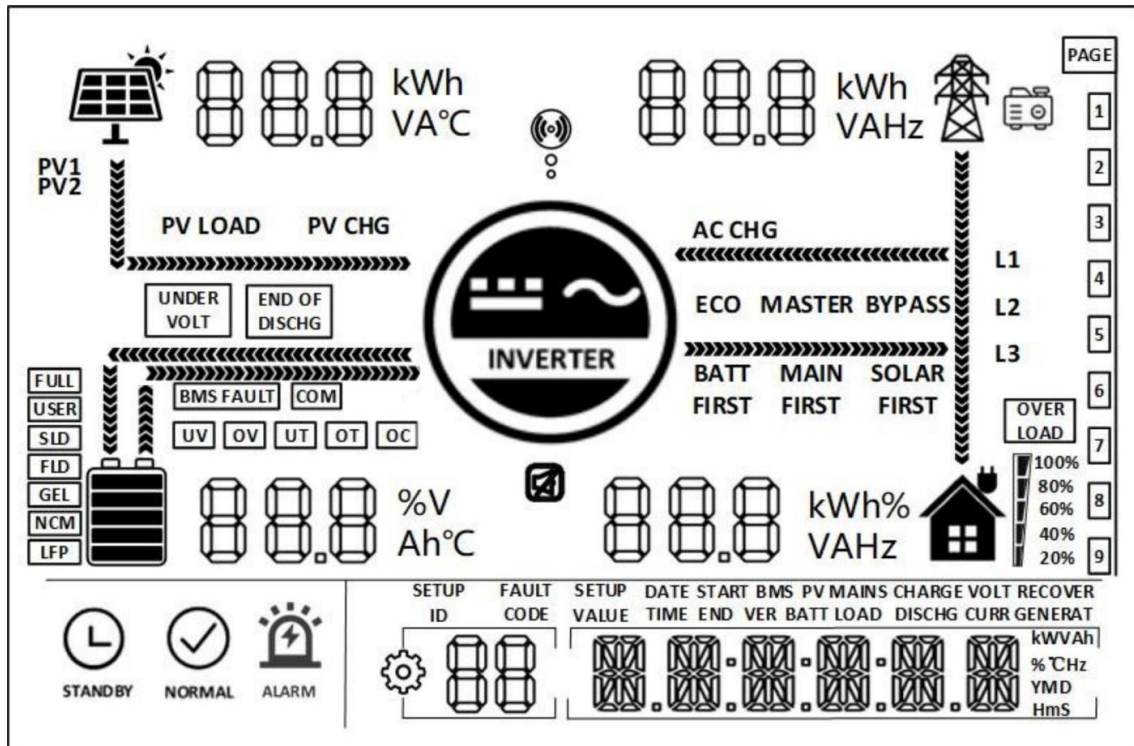

Icon	Description	Icon	Description
	Solar Panel		Grid
	Battery		Generator
	Inverter Working Status		Home load
	The inverter is communicating with the data collector		The buzzer is in mute mode
	Power Flow Direction		
	The inverter is in standby mode		The inverter is working normally
	There is a fault		Settings
	Load power: 80%–100%		SOC: 80%–100%
	Load power: 60%–79%		SOC: 60%–79%
	Load power: 40%–59%		SOC: 40%–59%
	Load power: 20%–39%		SOC: 20%–39%
	Load power: 5%–19%		SOC: 5%–19%

UNDER VOLT	Battery under-voltage	END OF DISCHG	Battery over-discharge
OVER LOAD	Overload	BMS FAULT	BMS fault
COM	System communication error	UV	System under-voltage
OV	System overvoltage	UT	System temperature too low
OT	Too high system temperature	OC	System over-current
FULL	Battery full power	USER	User-defined battery
SLD	Sealed lead-acid battery	FLD	Flooded lead-acid battery
GEL	Gel lead-acid battery	NCM	Ternary Li-ion battery
LFP	LFP Li-ion battery	ECO	Energy-saving mode
PV LOAD	PV energy is carrying the load	PV CHG	PV power is charging the battery
AC CHG	AC input power is charging the battery	MAINS FIRST	The output mode of the inverter is mains first
BYPASS	The output mode of the inverter is mains bypass	SOLAR FIRST	The output mode of the inverter is Solar first
BATT FIRST	The output mode of the inverter is battery first		

■ View real-time data

On the screen, press the UP/DOWN button to view real-time data of the inverter in operation.

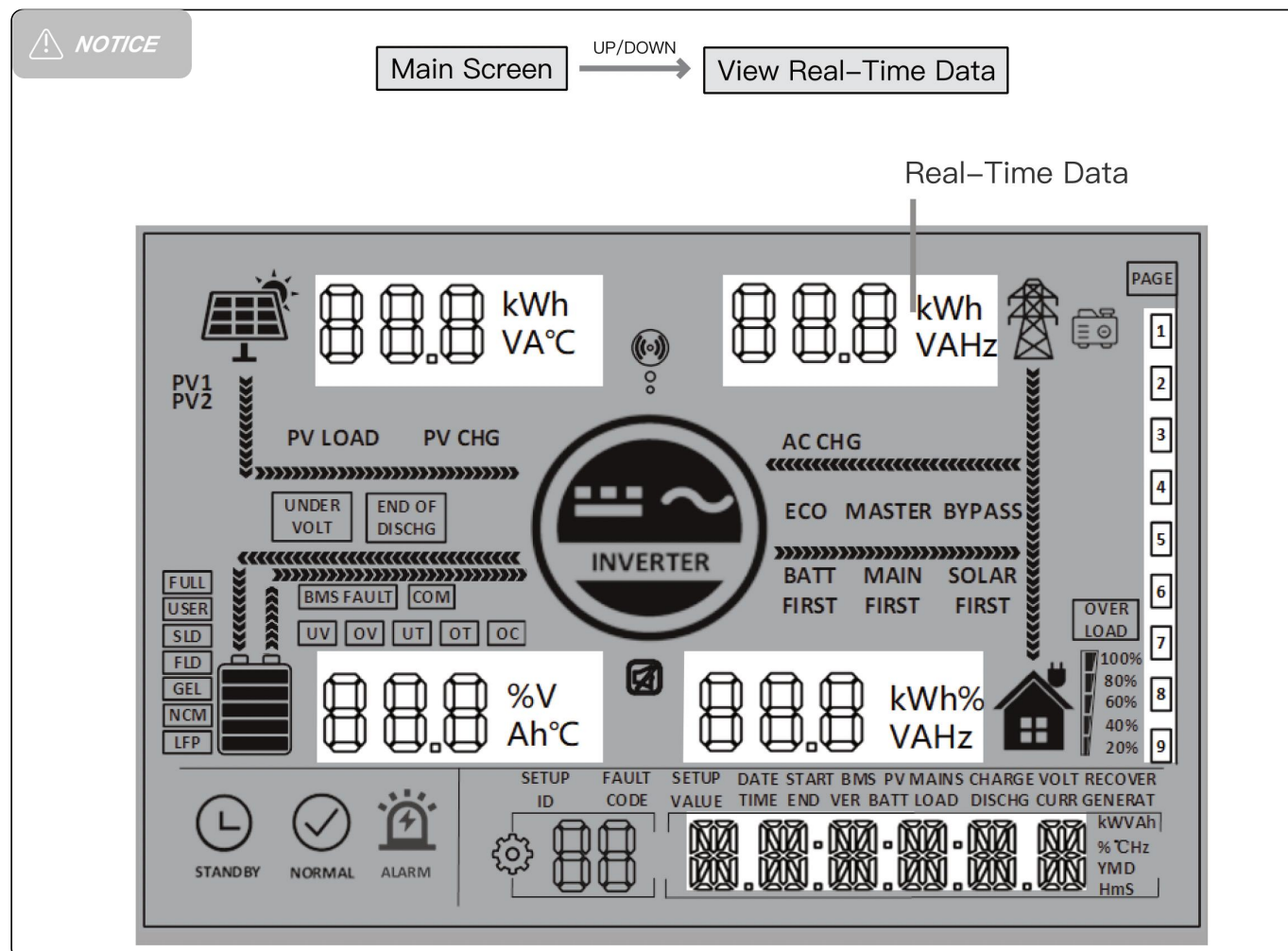

Page	PV	Battery	AC input	Load	General
1	PV input voltage	Battery voltage	AC input voltage	Phase voltage	Current time
2	PV input current	Battery current	AC input current	Phase current	Current date
3	PV input power	Battery voltage	Total AC input power	Active power	Total PV power generation
4	Today's photovoltaic power generation in kWh	Battery current	Today's AC charging kWh	Apparent power	Total load electricity consumption
5	PV side radiator temperature	INV radiator temperature	AC frequency	AC output frequency	RS485 address
6	/	Rated battery voltage	Bus voltage	Rated output power	Software version
7	Max. PV charging current	Max. battery charge current	Max. AC charging current	Total AC output active power	/
8			/	Total AC output apparent power	/

5.2 Setting

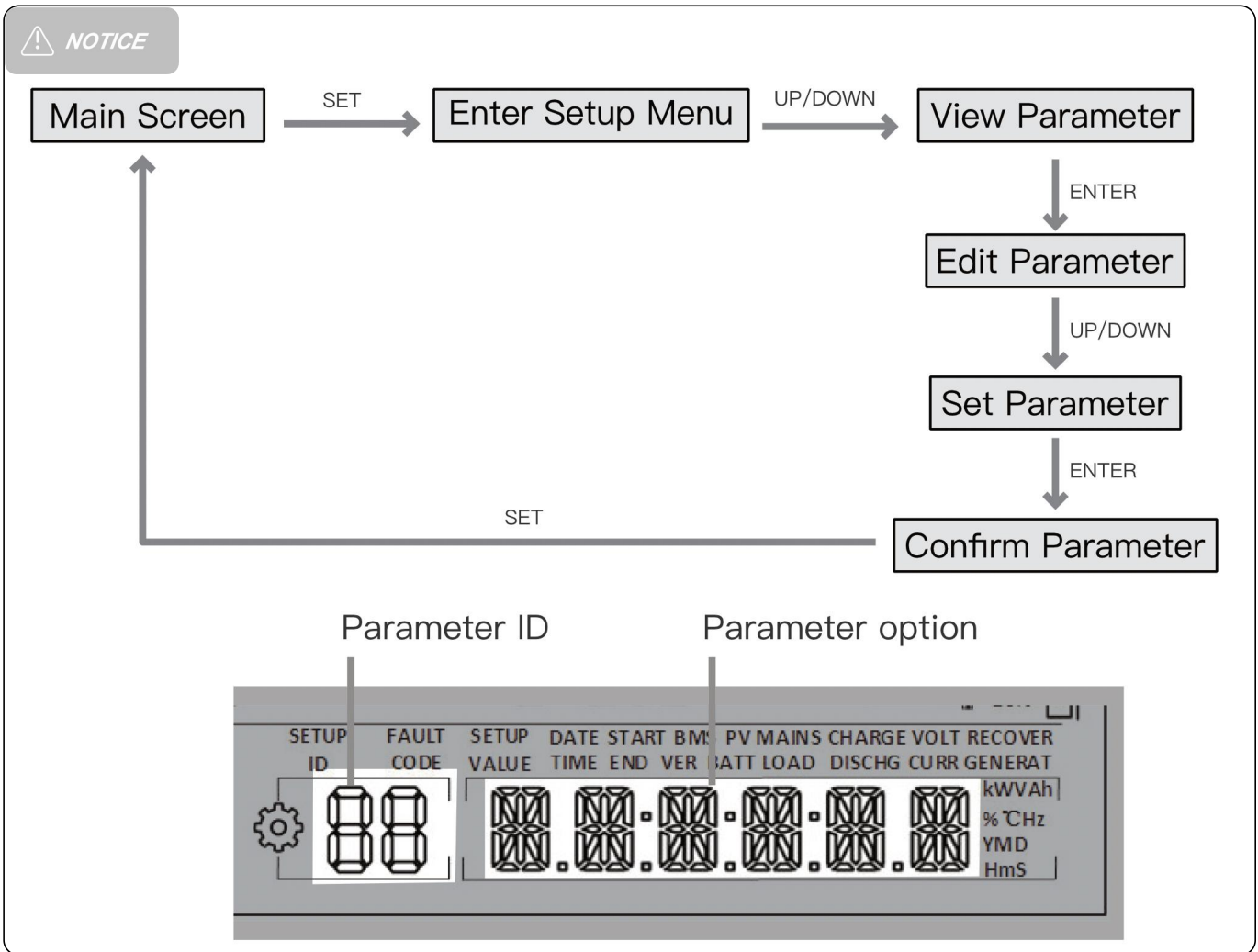

ID	Parameter	Option	Description
00	Exit	ESC	Exit the setup menu.
01	AC output mode	UTI	<p>PV energy priority with the load, When PV power is insufficient, the grid and PV jointly supply the load. When PV power exceeds the load demand, the surplus charges the battery.</p> <p>Grid charging is activated only when the battery is over-discharged. (06 Settings as "OSO(only PV)", the grid power will not charge), the battery is only discharged when off the grid.</p>
		SBU	<p>Prioritises the use of PV to power the load and switches back to the grid to power the load only when the battery voltage is lower than the set value in parameter item [4] (when connected to the BMS, according to item [61]).</p> <p>When the battery voltage is higher than the value set in parameter [5] (when connected to the BMS, according to item [62]), it switches back to the PV from the grid to supply the load.</p>
		SUB default	<p>PV energy first used for charging, the remaining energy supply load,when PV energy is insufficient, it is supplemented by the grid , the grid energy is first supplied to the load and second used for charging(if 06 Settings as "OSO(only PV)" ,the grid energy will not used for charging).</p>
		SOL	<p>PV first mode. When the PV power is unavailable or the battery voltage is lower than the set value in the item 4, it will switch to the grid mode</p>
02	AC output frequency	50.0 default	<p>In grid mode the AC output frequency will adapt to the grid frequency, otherwise the output will follow the preset values.</p>
		60.0	
04	Voltage point of battery switch to grid	43.6 default	<p>When parameter [01]= SBU/SOL, output source will switch to grid from battery when the battery voltage below the preset value.</p> <p>Setting range: 40~52V.</p>
05	Voltage point of grid switch to battery	56.8 default	<p>When parameter [01]=SBU/SOL, output source will switch to battery from grid when the battery voltage above the preset value.</p> <p>Setting range: 48~60V.</p>

06	Battery charging mode	SNU default	PV and grid hybrid charging, with PV charging prioritized. When PV energy is insufficient, mains charging supplements it. When PV energy is sufficient, mains charging stops. Note: PV and mains can only charge simultaneously when the mains bypass output is loaded. During inverter operation, only PV charging can be activated.
		OSO	Only PV charging, without activating grid charging.
07	Battery charging current	200A default	Corresponding to ASP48160SH3, setting range: 0~300A.
		275A default	Corresponding to ASP48180SH3, setting range: 0~360A.
			Corresponding to ASP48200SH3, setting range: 0~360A.
08	Battery type	USER	User-defined, user can set all battery parameter.
		SLd	Sealed lead-acid battery.
		FLd	Flooded lead-acid battery.
		GEL default	Gel lead-acid battery.
		L14/ L15/ L16	L14/ L15/ L16 lithium iron phosphate batteries, corresponding to lithium iron phosphate batteries 14, 15, 16 series.
		N13/ N14	Ternary lithium batteries, N13/N14, corresponding to ternary lithium batteries 13 series, 14 series.
		No bat	No battery.
09	Boost charging voltage	57.6V default	Setting range 48V~58.4V, step 0.4V, valid when battery type is custom and lithium battery.
10	Boost charging maximum time	120 default	Boost charging maximum time setting, refers to the constant voltage charging when the voltage reaches the parameter [09] setting voltage maximum charging time, set the range of 5min~900min, step of 5 minutes.
11	Battery float charging voltage	55.2 default	Setting range 48V~58.4V, step 0.4V, this parameter can not be set after the BMS communication is successful.
12	Battery over - discharge voltage (delayed shutdown)	42 default	When the battery voltage is lower than the judgement point, and triggers the parameter [13] , the inverter output is switched off, the setting range is 40V~48V.
13	Battery over-discharge delay time	5 default	The battery voltage is lower than parameter [12] , and the inverter output is switched off after triggering the delay time set in this parameter, the setting range is 5s~50s, the step is 5s.

14	Battery under-voltage alarm point	44 default	When the battery voltage is lower than this judgement point, the device will under-voltage alarm, the output will not be switched off, the setting range is 40V~52V, the step is 0.4V.
15	Battery discharge limiting voltage	40 default	When the battery voltage is lower than this parameter value, the output will be turned off immediately. The setting range is 40V~52V, the step is 0.4V.
16	Battery equalization charging	DIS	Disable equalization charging.
		ENA default	Enable equalization charging, valid when battery type is FLd, SLd, and USER.
17	Battery equalization charging voltage	58	Setting range 48V~58V in 0.4V steps, valid when battery type is FLd, SLd, and USER.
18	Battery equalization charging duration	120	Setting range 5min~900min in 5 min steps, valid when battery type is FLd, SLd, and USER.
19	Battery equalization charging delay time	240	Setting range 5min~900min in 5 minute steps, valid when battery type is FLd, SLd, and USER.
20	Battery equalization charging interval	30	Setting range 0~30 days in 1 day steps, valid when battery type is FLd, SLd, and USER.
21	Battery equalization charging stop-start	DIS default	Start equalization charging immediately.
		ENA	Stop equalization charging immediately.
22	Energy-saving mode	DIS default	Disable energy-saving mode.
		ENA	Enable energy-saving mode, when the load power is less than 25W, the output of the inverter will switch off after a 5-minute delay. When the load exceeds 50W, the inverter will restart automatically.
23	Overload automatic restart	DIS	Disable overload automatic restart, if an overload occurs to shut down the output, the machine will not be restored to power on again.
		ENA default	Enable overload automatic restart. If an overload occurs that shuts down the output, the machine delays for 3 minutes before restarting the output. After accumulating 5 times, it will not restart again.
25	Buzzer alarm	DIS	Disable buzzer alarm.
		ENA default	Enable buzzer alarm.
26	Mode change alarm	DIS	Disable alarm prompt when the status of the main input source changes.
		ENA default	Enable alarm prompt when the status of the main input source changes.

27	Inverter overload switch to bypass	DIS	Disable automatic switching to grid to power the load when the inverter is overloaded.
		ENA default	When the inverter is overloaded, it automatically switches to grid to power the load.
28	Grid charging current	150A	Corresponds to ASP48160SH3, setting range: 0~300A.
		180A	Corresponds to ASP48180SH3, setting range:0~360A.
		180A	Corresponds to ASP48200SH3, setting range: 0~360A.
29	BMS fault causes the battery to stop working.	DIS default	Disable BMS Faulty battery stops working.
		ENA	Enable BMS Faulty battery stops working.
30	RS485 communication address	ID: 1	RS485 address setting range: 1~253.
31	AC output mode (can be set in the standby mode only)	SIG default	When single inverter is used, the default is SIG mode .
		PAL	In parallel operation.
32	RS485 communication	DIS default	Disable the BMS communication function.
		485	RS485 BMS communication function.
		CAN	CAN BMS communication function.
33	BMS communication	When item [32] = 485 / CAN , the corresponding lithium battery manufacturer brand should be selected for communication.	
		WOW default	<p>485 protocol: PAC=PACE, RDA=RITAR, AOG=ALLGRAND , OLT=OLITER, CEF=CFE, XYD=SUNWODA, DAQ=DYNESS, WOW=SRNE, PYL=PYLONTECH , POW=POWMr, VOL=VILION, SGP=SGP, GSL Energy, PYT=Pylon tech 2</p> <p>CAN protocol: UZE=YUZE, SGP=SGP, GSL Energy, PYT=Pylon tech 2</p>
34	On-grid and anti-reverse current	DIS default	Disable this function.

		ON GRD	<p>When parameter [01]=UTI, PV energy will be prioritized for load supply. After meeting the load demand, the remaining electricity will be fed back to the grid, and any further excess energy will be used to charge the battery.</p> <p>When parameter [01]=SUB, PV energy will prioritize charging the battery. After meeting the battery demand, the remaining electricity will be used to power the load (if the remaining electricity is insufficient for the load, the remaining PV power will be mixed with grid power to supply the load), and any additional excess energy will be fed back to the grid.</p>
		LM HOME LOAD	<p>When parameter [01]=UTI, PV energy will be prioritized for load supply. Excess energy will be subject to anti-backflow control, and any remaining excess energy will be used to charge the battery.</p> <p>When parameter [01]=SUB, PV energy will be prioritized for charging. After meeting the battery's requirements, the remaining energy will be used for load supply, and any further excess energy will be subject to anti-backflow control.</p>
35	Battery under-voltage recovery point	52V default	When the battery is under-voltage, the battery voltage needs to be higher than this setting value in order to restore the battery inverter AC output, setting range: 44V~54.4V.
37	Battery full charge and recharging recovery point	52V default	Inverter stops charging when the battery is full. Inverter resumes charging when the battery voltage below this value. Setting range: 44V~54V.
38	AC output phase voltage	230V default	Setting range: 200/208/220/230/240Vac.
39	Charging current limiting method (when BMS is enabled)	[SET] The maximum battery charging current is limited according to the setting in [07].	
		[BMS] Default Maximum battery charging current is limited according to the current limit value of the BMS.	
		[INV] Maximum battery charging current is limited by the machine's derating logic.	
40	1st slot grid start charging	00:00:00 default	Setting range: 00:00:00-23:59:00.
41	1st slot grid end charging	00:00:00 default	Setting range: 00:00:00-23:59:00.
42	2nd slot grid start charging	00:00:00 default	Setting range: 00:00:00-23:59:00.
43	2nd slot grid end charging	00:00:00 default	Setting range: 00:00:00-23:59:00.

44	3rd slot grid start charging	00:00:00 default	Setting range: 00:00:00-23:59:00.
45	3rd slot grid end charging	00:00:00 default	Setting range: 00:00:00-23:59:00.
46	Time slot grid charging function	DIS default	Disable this function.
		ENA	When the segmented scheduled grid charging function is enabled, grid charging will only be performed during the set charging time periods.
47	1st slot battery start discharging	00:00:00 default	Setting range: 00:00:00-23:59:00.
48	1st slot battery end discharging	00:00:00 default	Setting range: 00:00:00-23:59:00.
49	2nd slot battery start discharging	00:00:00 default	Setting range: 00:00:00-23:59:00.
50	2nd slot battery end discharging	00:00:00 default	Setting range: 00:00:00-23:59:00.
51	3rd slot battery start discharging	00:00:00 default	Setting range: 00:00:00-23:59:00.
52	3rd slot battery end discharging	00:00:00 default	Setting range: 00:00:00-23:59:00.
53	Time slot battery discharging function	DIS default	Disable this function.
		ENA	After enabling the segmented timed battery discharge function, the battery will discharge only during the specified discharge period.
54	Local date	00:00:00	YY/MM/DD. Setting range: 00:01:01-99:12:31.
55	Local time	00:00:00	Setting range: 00:00:00-23:59:59.
56	Leakage current detection protection	DIS default	Disable detecting Leakage current value.
		ENA	Enable detecting Leakage current value.
57	Stop charging current	3	Charging stops when the charging current is less than this setting (unit: A).
58	Discharging alarm SOC setting	15	Triggers an alarm when the battery SOC is less than the set value (unit: %, valid only when BMS communication is normal).
59	Discharging cut-off SOC setting	5	Stops discharging when the battery SOC is less than the set value (unit: %, valid only when BMS communication is normal).
60	Charging cut-off SOC setting	100	Stops charging when the battery SOC is higher than the set value (unit: %, valid only when BMS communication is normal).

61	Switching to grid SOC setting	10	Switch to grid power when the battery SOC is less than this setting value (unit: %, valid only when BMS communication is normal).
62	Switching to inverter output SOC setting	100	Switches to inverter output mode when SOC is higher than this setting value (unit: %, valid only when BMS communication is normal).
63	N-PE bonding automatic switching function	DIS default	Disable automatic switching of N-PE connections.
		ENA	Enable automatic switching of N-PE connections.
67	on-grid power setting	0 default	Setting range: 0 to inverter rated power.
68	Output phase - angle setting	Three-phase with N line	For three-phase four-wire system, where the mains input has a N line connected.
		Three-phase without N line (Not settable by default)	For three-phase three-wire system, where the mains input has no N line connected.
70	Insulation impedance detection	DIS default	Disable detecting insulation impedance value.
		ENA	Enable detecting insulation impedance value.
72	Battery grid-connected discharge enable	DIS default	The battery is not permitted to discharge to the grid.
		ENA	The battery is permitted to discharge to the grid.
73	Generator charging current setting	150A default	Configurable when the generator is GEN_IN, with a maximum of 300A for ASP48160SH3
		180A default	Configurable when the generator is GEN_IN, with a maximum of 360A for ASP48180SH3
		180A default	Configurable when the generator is GEN_IN, with a maximum of 360A for ASP48200SH3
74	Generator power setting	32kW	Configurable when the generator is GEN_IN. For ASP48160SH3, the maximum is 32kW, corresponding to a maximum grid input of 16kW for charging and 16kW for load supply.
		36kW	Configurable when the generator is GEN_IN. For ASP48180SH3, the maximum is 36kW, corresponding to a maximum grid input of 18kW for charging and 18kW for load supply.
		40kW	Configurable when the generator is GEN_IN. For ASP48200SH3, the maximum is 40kW, corresponding to a maximum grid input of 20kW for charging and 20kW for load supply.

76	External CT transformation ratio	2500	Setting range: 0~5000
77	External CT anti-backflow error power	100W default	It can be set between 0W and 500W, which means that in order to prevent power sampling errors, 0-500W of electricity is drawn from the grid to ensure that there is no backflow at all.
79	AFCI Enable	DIS default	Disable AFCI function.
		1-10	Enable AFCI function. Detection Threshold: 1-10
80	AFCI fault manual clearing	NULL default	Do not clear.
		CLEAR	Manually clear the AFCI fault.
81	Generator operating mode	GEN IN default	Generator interface used as generator function input.
		AC OUT	Generator interface used as secondary load port output.
82	CT manual enabling	NO CT	No CT input.
		TO INV	CT direction set to inverter flow as positive direction.
		TO GRD	CT direction set to grid flow as positive direction.

5.3 AC Output Mode

The AC output mode corresponds to parameter setting item 01 and 34, which allows the user to set the AC output power source manually.

■ Utility Priority Output 01 UTI

Utility priority for power supply. It will only switch to the inverter when the grid power is cut off. **(Priority: PV > Utility > Battery)**

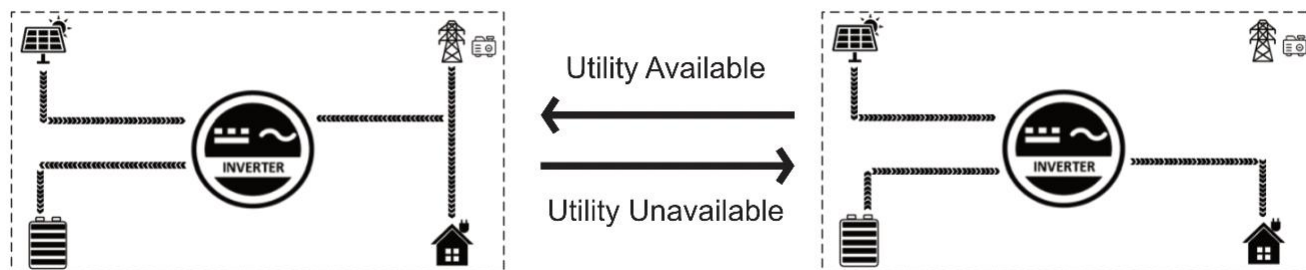

■ PV and Utility hybrid loading 01 SUB (default)

PV priority charging; When PV power is insufficient, utility power and PV will perform hybrid charging (when item 06 is set to "PV-only charging", utility power will not be used for charging), and utility power will supply the load. When PV power meets the charging demand but cannot meet the load demand, PV and utility power will perform hybrid loading, and the battery will only discharge in off-grid mode.

(Priority: Utility > PV > Battery)

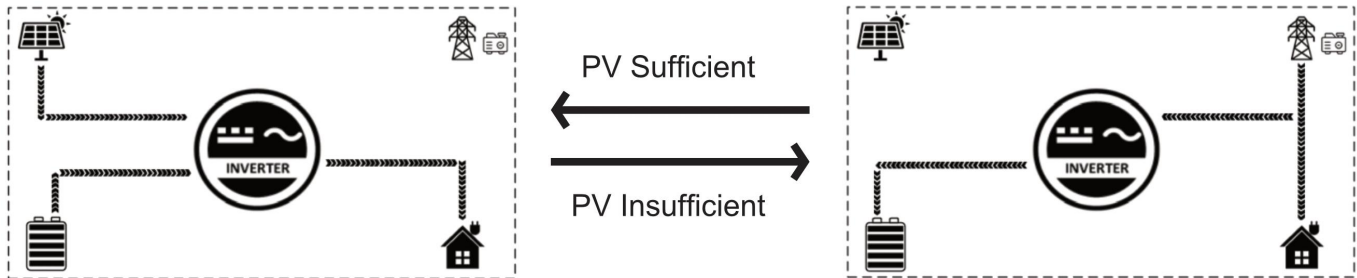

■ PV Priority Output 01 SOL

PV prioritizes power supply to the load. When PV meets the load demand, the excess power will charge the battery. When PV energy is insufficient, the battery will supplement energy to power the load. When PV is invalid, it will switch to utility power supply, and finally use battery power supply. When PV energy is insufficient, and when the battery level is lower than the parameter (Battery to utility) or the SOC setting value for switching to utility, it will switch to utility power supply for the load and charging. PV charges when there is no load. This mode can maximize the use of PV power generation while maintaining battery capacity, and is suitable for areas with stable power grids.

(Priority: PV > Utility > Battery)

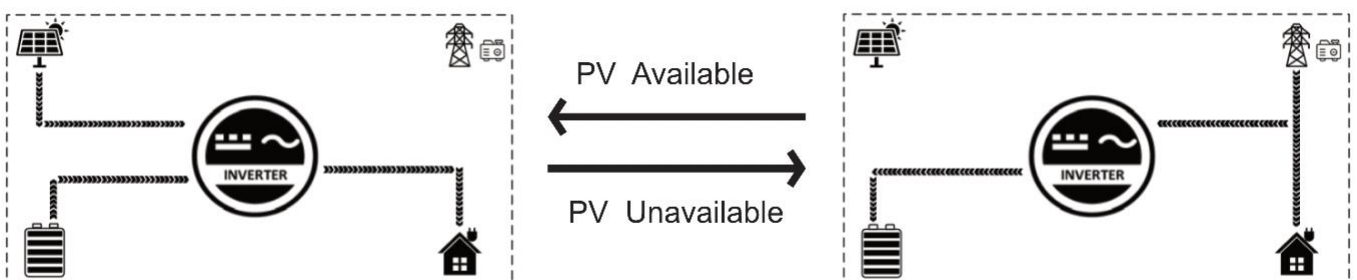

■ Inverter Priority Output 01 SBU

The PV will supply power to the loads on a priority basis. If the PV is insufficient or unavailable, the battery will be used as a supplement to supply power to the load. When the battery voltage touches the value of parameter [04] (Voltage point of battery switch to utility), it will switch to utility power supply to the load (without BMS connected) / When the BMS is connected and the Li-ion battery SOC touches the value of parameter [61] (Switching to utility SOC setting), it will switch to utility power supply to the load. This mode maximises the use of DC energy, and it is

suitable for the areas where the utility power is stable.

(Priority: PV > Battery > Utility)

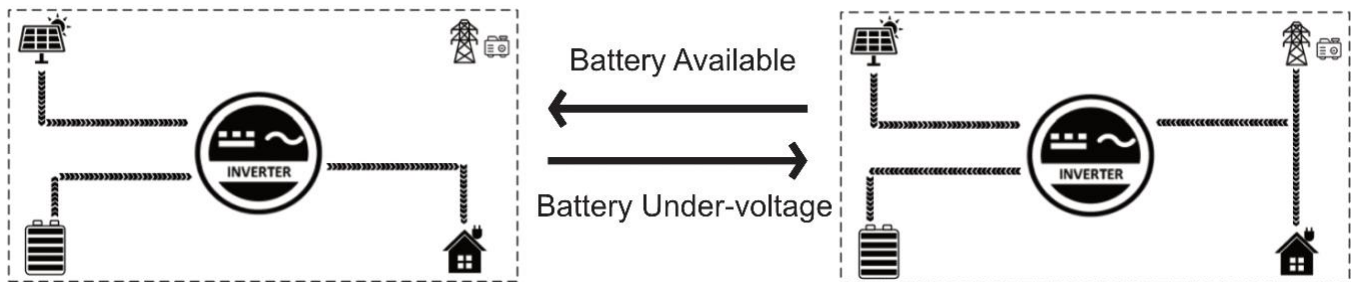

5.4 Battery Charging Mode

The charging mode corresponds to parameter [06], which allows the user to set the charging mode manually.

■ Hybrid Charging SNU (default)

PV and utility power charge the battery at the same time, with PV taking priority and mains power acting as a supplement when PV is insufficient. This is the fastest charging method and is suitable for areas with insufficient power supply, providing sufficient backup power for users. **(Priority: PV > Utility)**

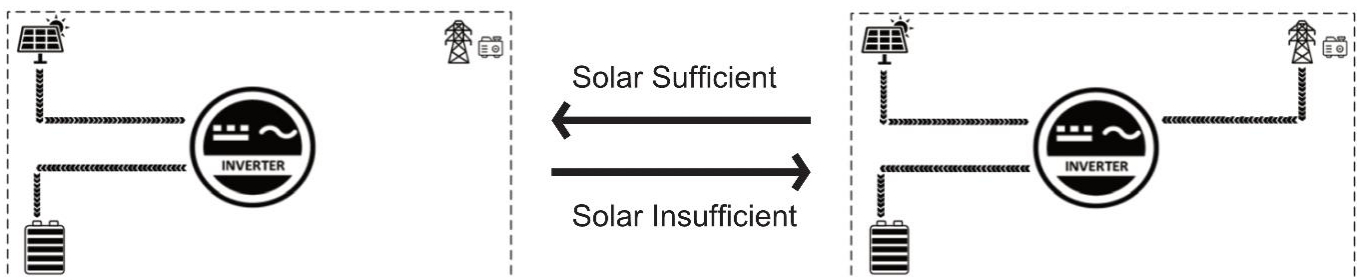

■ Only PV Charging OSO

Only PV power is used to charge the battery, without starting the utility charging. This is the most energy-efficient method, with all battery power coming from solar energy, and is usually used in areas with good radiation conditions.

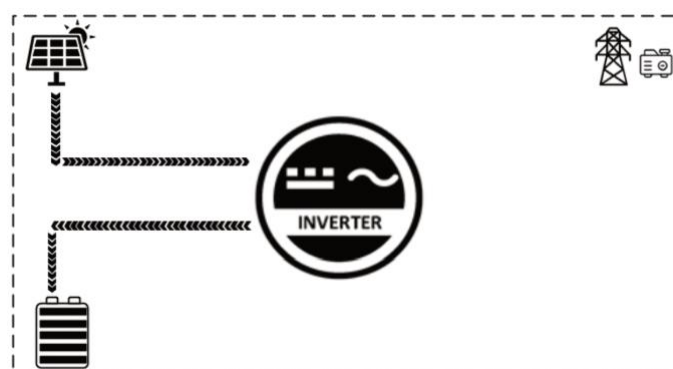

5.5 Time-slot Charging/Discharging Function

ASP SH3 series is equipped with time-slot charging / discharging function, users can set different charging/discharging time slots according to the local peak and valley electricity price, so as to make efficient use of utility power and PV energy. When the utility price is expensive, the battery can be used to supply power to the loads. When the utility price is cheap, the utility power can be used to supply to the loads and charge, which can help users save the electricity bill to the greatest extent. Users can turn on/off the time-sharing charging/discharging function in the setting menu parameters [46] and [53], and set the charging and discharging time periods in parameters [40-45], [47-52] for timed mains charging start/time setting and timed battery discharging start/time setting. Here is a case example to help users understand the function.

NOTICE

Before using this function for the first time, please set the local time in parameter [54], [55], then the user can set the corresponding time slot according to the local peak and valley tariff charges.

Peak-Valley Electricity Tariff

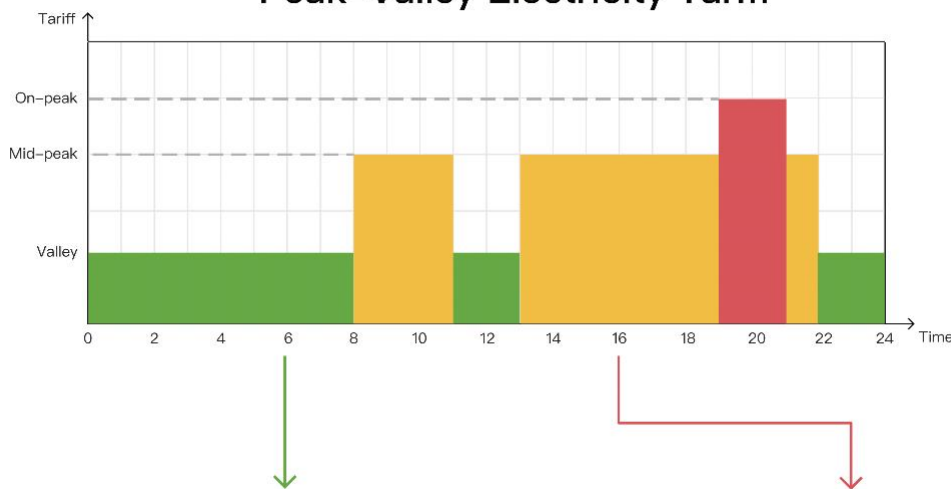

Time-slot Utility Charging & Loading Function



With 3 definable periods, the user can freely set the mains charging/supplying power time within the range of 00:00 to 23:59. During the time period set by the user, if PV energy is available, PV energy will be used first, and if PV energy is not available or insufficient, utility energy will be used as a supplement.

Time-slot Battery Discharging Function



With 3 definable time periods, users can freely set the battery discharge time within the range of 00:00 to 23:59. During the time set by the user, the inverter will give priority to the battery inverter to carry the load, and if the battery power is insufficient, the inverter will automatically switch to mains power to ensure stable operation of the load.

5.6 Battery Parameters

■ Lead-acid battery

Battery type Parameters	Sealed lead acid battery (SLD)	Gel lead acid battery (GEL)	Flooded lead acid battery (FLD)	User-defined (USE)
Overvoltage Disconnect Voltage	60V	60V	60V	60V
Equalization Charging Voltage	58V	56.8V	58V	40 ~ 60V settable
Boost Charging Voltage	57.6V	56.8V	57.6V	40 ~ 60V settable
Float Charging Voltage	55.2V	55.2V	55.2V	40 ~ 60V settable
Undervoltage Alarm Voltage	44V	44V	44V	40 ~ 60V settable
Undervoltage Disconnect Voltage	42V	42V	42V	40 ~ 60V settable
Discharge Limit Voltage	40V	40V	40V	40 ~ 60V settable
Over-discharge Delay Time	5s	5s	5s	1 ~ 30s settable
Equalization Charging Duration	120 min	-	120 min	0 ~ 600 min settable
Equalization Charging Cycle	30d	-	30d	0 ~ 250d settable
Bulk Charging Cycle	120m	120m	120m	10 ~ 900m settable

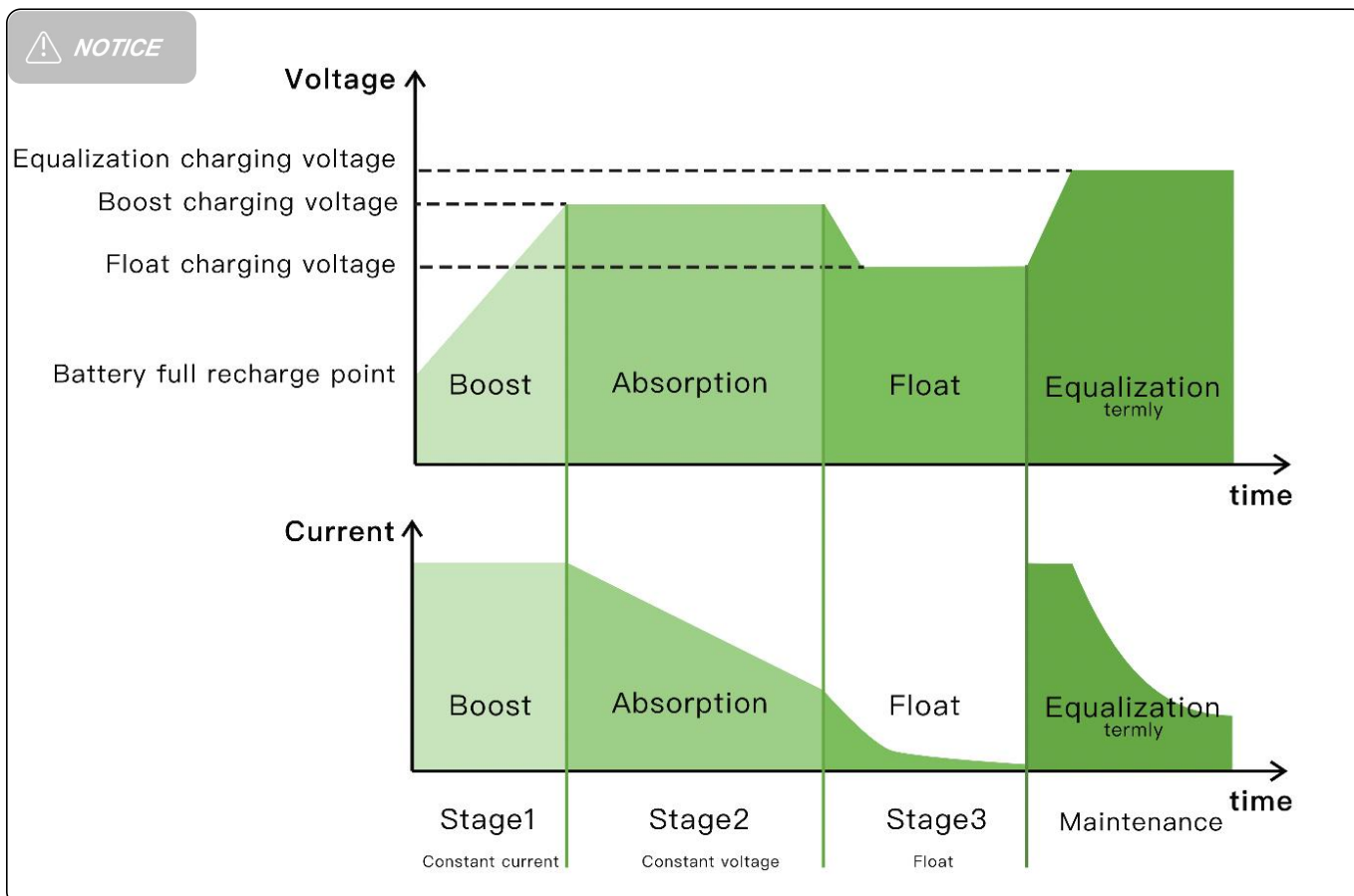

■ Lithium-ion Battery

Battery type Parameters	Ternary (N13)	Ternary (N14)	LFP (L16)	LFP (L15)	LFP (L14)	Adjustable
Ovoltage Disconnect Voltage	60V	60V	60V	60V	60V	60V
Equalization Charging Voltage	-	-	-	-	-	40 ~ 60V settable
Boost Charging Voltage	53.2V	57.6V	56.8V	53.2V	49.2V	40 ~ 60V settable
Float Charging Voltage	53.2V	57.6V	56.8V	53.2V	49.2V	40 ~ 60V settable
Undervoltage Alarm Voltage	43.6V	46.8V	49.6V	46.4V	43.2V	40 ~ 60V settable
Undervoltage Disconnect Voltage	38.8V	42V	48.8V	45.6V	42V	40 ~ 60V settable
Discharge Limit Voltage	36.4V	39.2V	46.4V	43.6V	40.8V	40 ~ 60V settable
Over-discharge Delay Time	30s	30s	30s	30s	30s	1 ~ 30s settable
Equalization Charging Duration	-	-	-	-	-	0 ~ 600 min settable
Equalization Charging Cycle	-	-	-	-	-	0 ~ 250d settable
Boost Charging Cycle	120 min settable	120 min settable	120 min settable	120 min settable	120 min settable	10 ~ 900 min settable

 **NOTICE**

If no BMS is connected, the inverter will charge according to the battery voltage with a preset charging curve. When the inverter communicates with the BMS, it will follow the BMS instructions to perform a more complex stage charging process.

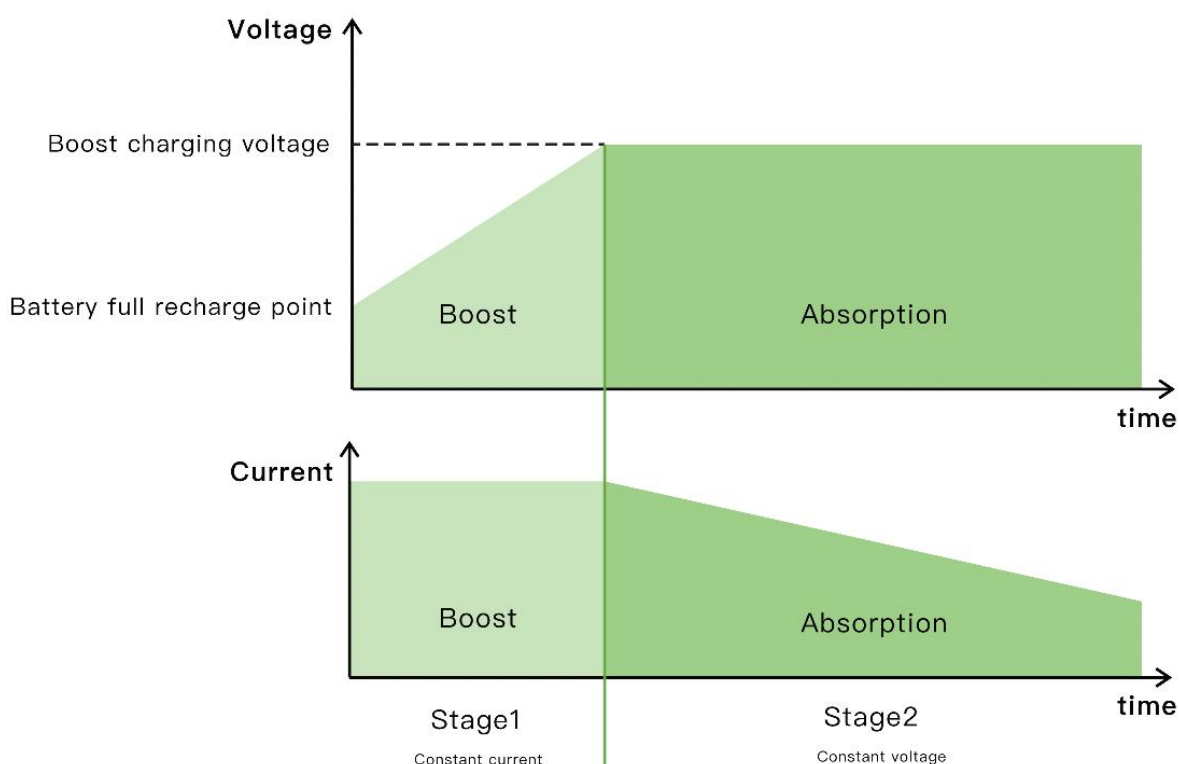

6.Communication

6.1 Product Overview

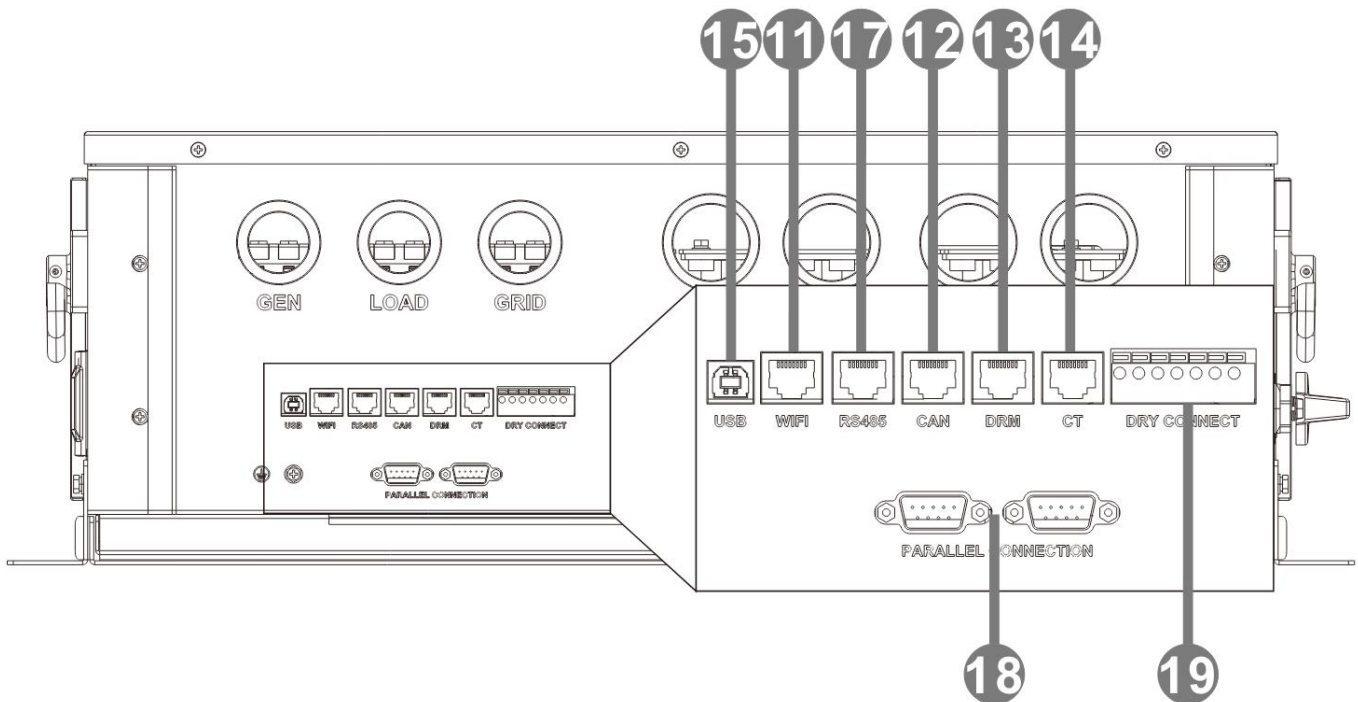

11	WiFi Port	12	CAN Port	13	DRM Port
14	CT Port	15	USB Port	17	RS485 Port
18	Parallel Port	19	Dry Contact Prot		

6.2 USB Communication Function

Users can use the host computer software to read and modify the device parameters through this port. If you need the installation package of the host computer software, you can download it from the official website of SRNE or contact us to get the installation package.

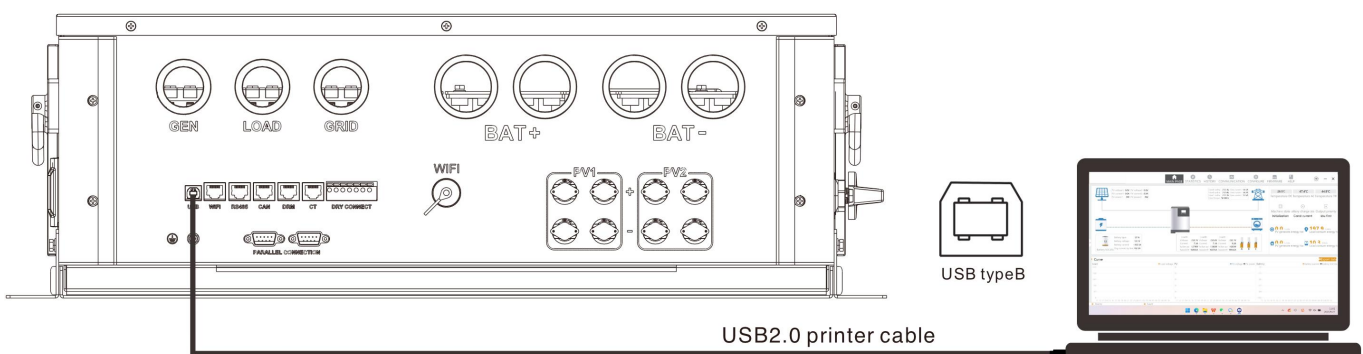

6.3 WiFi Communication Function

The WiFi port is used to connect to the Wi-Fi/GPRS logger module, which allows users to view the operating status and parameters of the inverter via mobile phone APP.

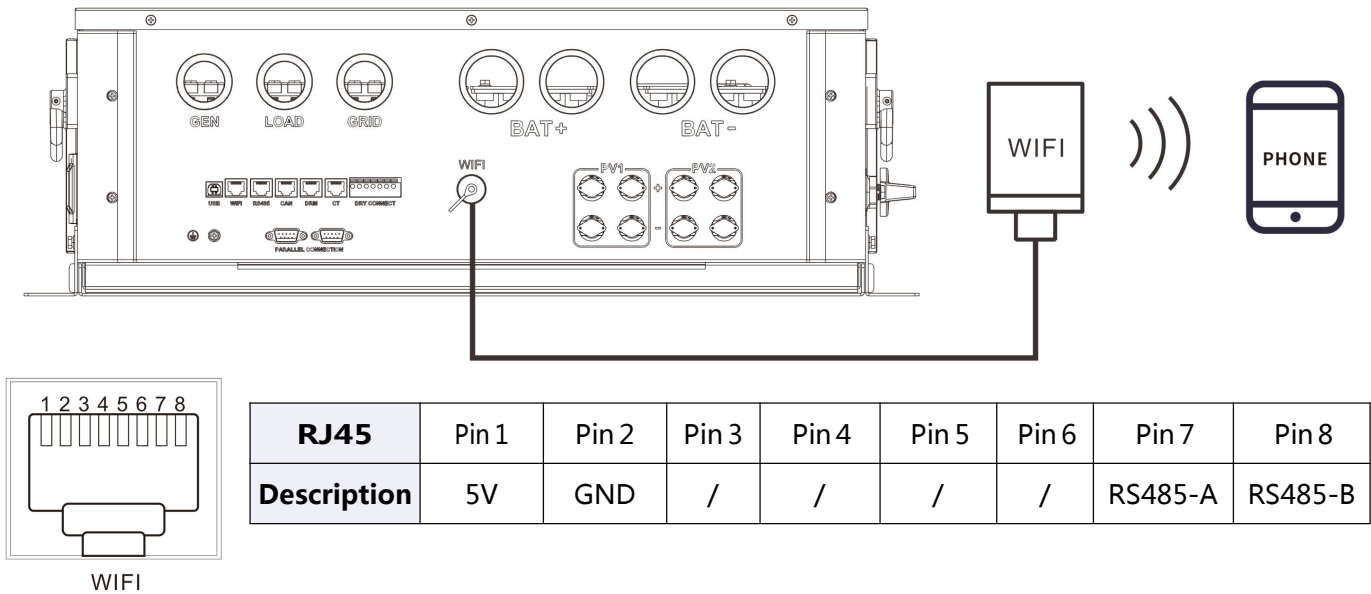

6.4 RS485/CAN Communication Function

The RS485/CAN communication port is used to connect to the BMS of Liion battery.

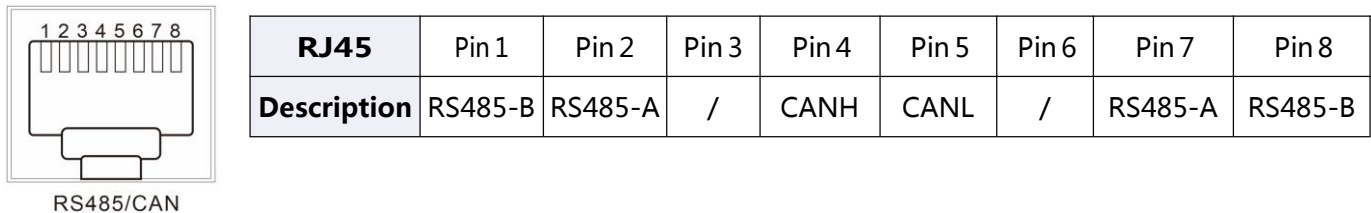

NOTICE

If you need to use the inverter to communicate with the lithium battery BMS, please contact us for the communication protocol or upgrade the inverter to the appropriate software programme.

6.5 Dry Contact Function

The dry contact port has 4 functions :

1. Remote switch on/off
2. Switching signal output
3. Battery temperature sampling
4. Generator remote start/stop

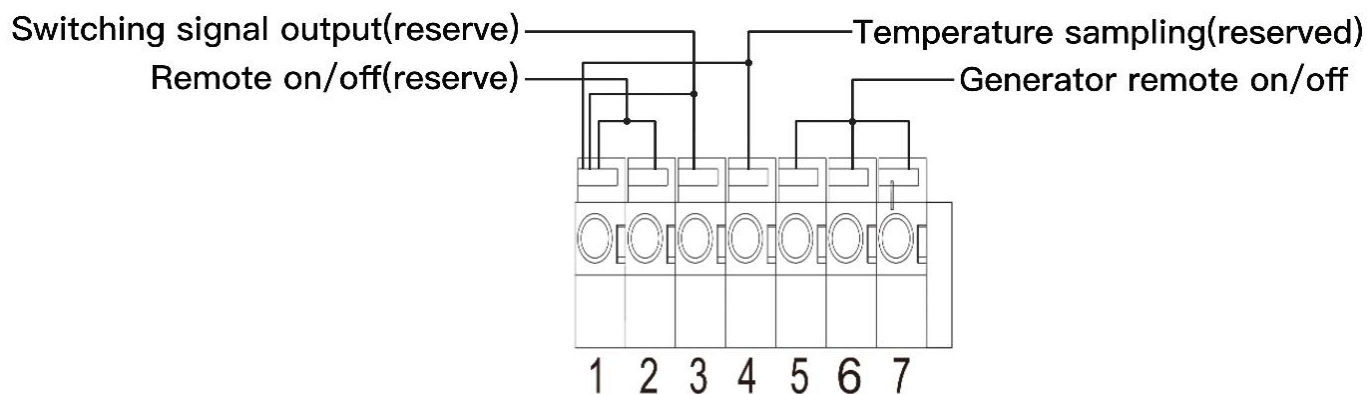

Function	Description
Remote switch on/off (reserved)	When pin 1 is connected with pin 2, the inverter will switched off the AC output. When pin1 is disconnected from pin2, the inverter outputs normally.
Switching signal output (reserved)	When the voltage of battery reaches the battery discharge limiting voltage (parameter [15]), pin 3 to pin 1 voltage is 0V. When the battery charging is normal, pin 3 to pin 1 voltage is 5V.
Temperature sampling (reserved)	Pin 1 & Pin 4 can be used for battery temperature sampling compensation.
Generator remote switch	When the voltage of battery reaches the battery under-voltage alarm point (parameter [14]) or voltage point of battery switch to utility (parameter [04]), pin 6 to pin 5 normally open, pin 7 to pin 5 normally close. When the voltage of battery reaches the voltage point of utility switch to battery (parameter [05]) or battery is full, pin 6 to pin 5 normally close, pin 7 to pin 5 normally open. (Pin 5/6/7 outputs 125Vac/1A, 230Vac/1A,30Vdc/1A)

NOTICE

If you need to use the remote start/stop function of the generator with dry contact, ensure that the generator has ATS and supports remote start / stop.

6.6 DRM(Only Australia)

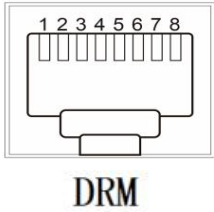

RJ45	Pin 1	Pin 2	Pin 3	Pin 4	Pin 5	Pin 6	Pin 7	Pin 8
Description	DRM5	DRM6	DRM7	DRM8	RefGen	COM/ DRM0	V+	V-

MODEL	RJ45 socket asserted by shorting pins		Requirement
	Pin 1	Pin 2	
DRM0	5	6	Operate the power-off device.
DRM5	1	5	Do not generate power to the grid.
DRM6	2	5	The power generation shall not exceed 50% of the rated power.
DRM7	3	5	The power generation shall not exceed 75% of the rated power, and reactive power shall be absorbed when possible.
DRM8	4	5	Increase power generation (limited by other active DRM).

6.7 Parallel Communication Function

- This port is used for parallel communication, through which the parallel modules can communicate with each other.
- Each inverter has two DB15 ports, one for the male connector and the other for the female connector.
- When connecting, make sure to connect the male connector of the inverter with the female connector of the inverter to be paralleled, or connect the female connector of the inverter to the male connector of the inverter to be paralleled.
- Do not connect the male connector of the inverter to its female connector.

Female connector

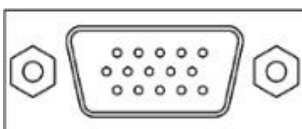

Male connector

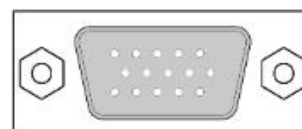

6.8 External CT Connection(Customer Optional)

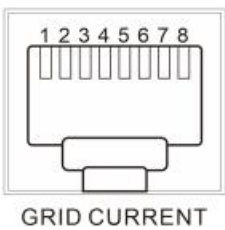
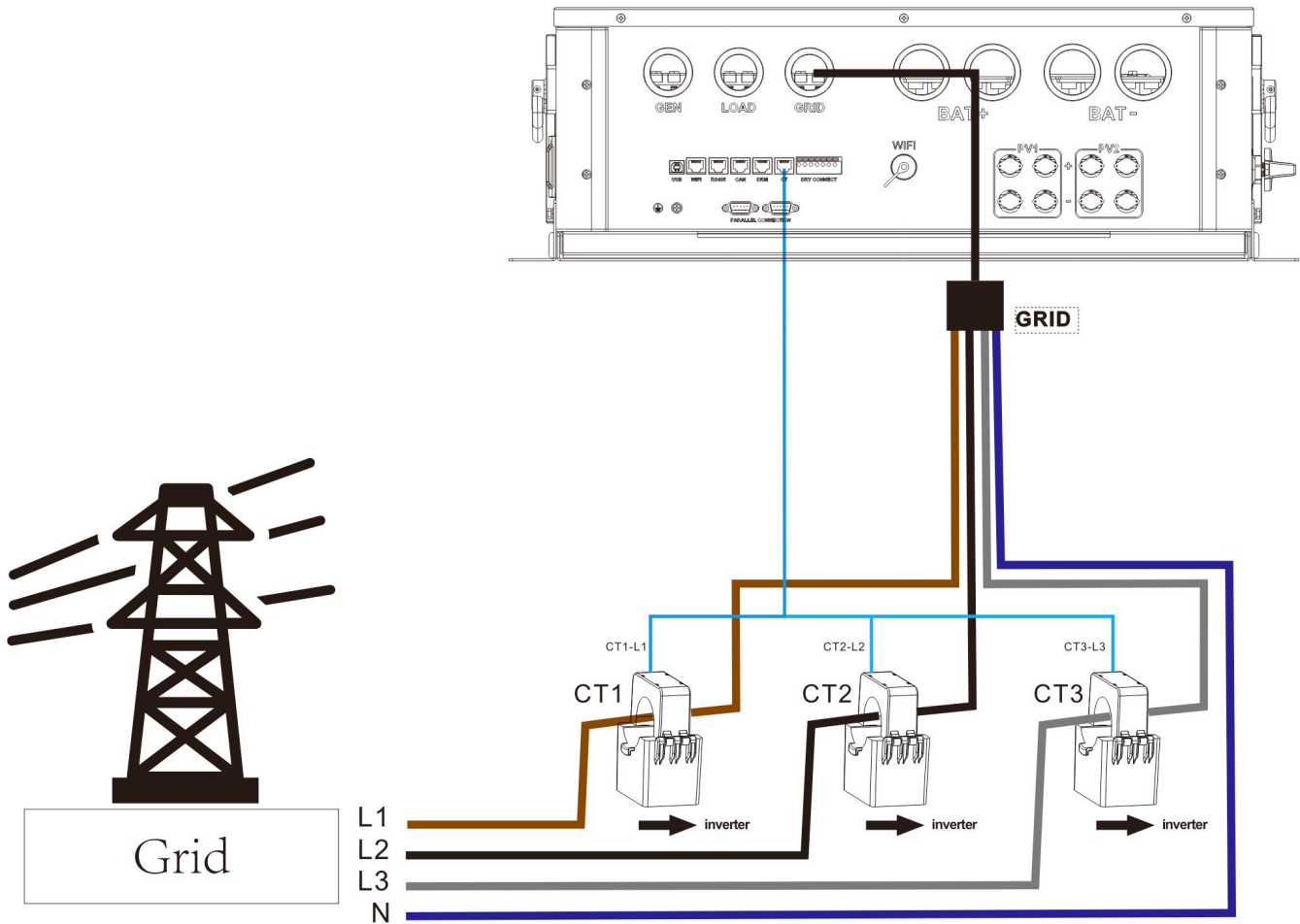

RJ45	Pin 1	Pin 2	Pin 3	Pin 4	Pin 5	Pin 6	Pin 7	Pin 8
Description	CT1+	CT1-	/	CT2+	CT2-	/	CT3+	CT3-

1. Split Core Current Transformer (CT) dimension: (mm)
2. Secondary output cable length is 4m.

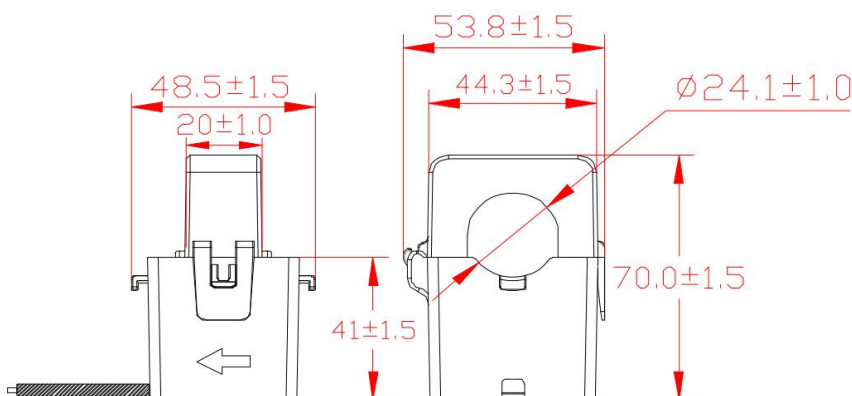

7. Fault Codes and Countermeasures

7.1 Fault Codes

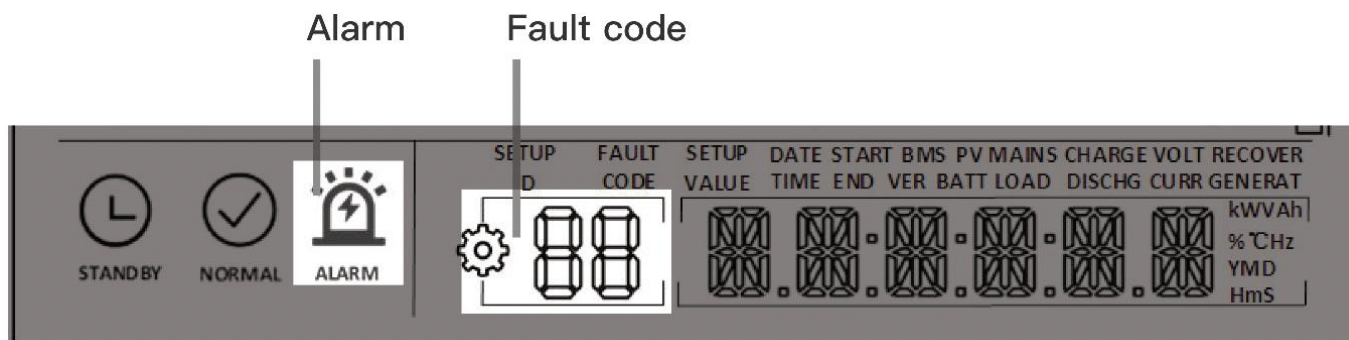

Fault Code	Fault name	Whether it affects the output or not	Description
[01]	BatVoltLow	No	Battery undervoltage alarm.
[02]	BatOverCurrSw	Yes	Battery discharge average current overcurrent (software protection).
[03]	BatOpen	Yes	Battery not-connected alarm.
[04]	BatLowEod	Yes	Battery undervoltage stop discharge alarm.
[05]	BatOverCurrHw	Yes	Battery overcurrent (hardware protection).
[06]	BatOverVolt	Yes	Charging overvoltage protection.
[07]	BusOverVoltHw	Yes	Bus overvoltage (hardware protection).
[08]	BusOverVoltSw	Yes	Bus overvoltage (software protection).
[09]	PvVoltHigh	No	PV overvoltage protection.
[10]	PvAFCErr	No	PV arc fault.
[11]	PvOCHw	No	Boost overcurrent (hardware protection).
[12]	SpiCommErr	Yes	SPI communication fault of master and slave chips.
[13]	OverloadBypass	Yes	Bypass overload protection.
[14]	OverloadInverter	Yes	Inverter overload protection.
[15]	AcOverCurrHw	Yes	Inverter overcurrent (hardware protection).
[16]	AuxDspReqOffPWM	Yes	Slave chip OFF request fault.
[17]	InvShort	Yes	Inverter short-circuit protection.
[18]	Bussoftfailed	Yes	Bus soft-start failure.
[19]	OverTemperMppt	No	PV radiator over-temperature protection.
[20]	OverTemperInv	Yes	Inverter heat dissipation over-temperature protection
[21]	FanFail	Yes	Fan blockage or failure fault.
[22]	EEPROM	Yes	Memory failure.
[23]	ModelNumErr	Yes	Model setting error.
[24]	Busdiff	Yes	Positive and negative bus voltage imbalance.

[25]	BusShort	Yes	Bus short-circuit.
[26]	RlyShort	Yes	Inverted AC Output Backfills to Bypass AC Input.
[27]	LinePhaselose	Yes	Grid input phase lose.
[28]	LinePhaseErr	Yes	Grid input phase error
[29]	BusVoltLow	Yes	Bus voltage undervoltage protection.
[30]	BatCapacityLow1	No	Alarm given when battery capacity rate is lower than 10% (setting BMS to enable validity).
[31]	BatCapacityLow2	No	Alarm given when battery capacity rate is lower than 5% (setting BMS to enable validity).
[32]	BatCapacityLowStop	Yes	Inverter stops when battery capacity is low (setting BMS to enable validity).
[33]	ControlCanFault	Yes	Control CAN fault in parallel operation.
[34]	CanCommFault	Yes	CAN communication fault in parallel operation.
[35]	ParaAddrErr	Yes	Parallel ID (communication address) setting error.
[36]	Balance currentOC	Yes	Balance bridge arm overcurrent failure.
[37]	ParaShareCurrErr	Yes	Parallel current sharing fault .
[38]	ParaBattVoltDiff	Yes	Large battery voltage difference in parallel mode.
[39]	ParaAcSrcDiff	Yes	Inconsistent AC input source in parallel mode.
[40]	ParaHwSynErr	Yes	Hardware synchronization signal error in parallel mode.
[41]	InvDcVoltErr	Yes	Inverter DC component of voltage abnormality.
[42]	SysFwVersionDiff	Yes	Inconsistent parallel operation program versions.
[43]	ParaLineContErr	Yes	Parallel wiring fault.
[44]	Serial number error	Yes	Serial number not set at factory.
[45]	Error setting of split-phase mode	Yes	[31] Incorrect settings for parallel operation mode.
[46]	MeterComErr	Yes	Meter communication error.
[48]	AFCIComErr	Yes	AFCI communication error.
[56]	Low insulation resistance fault	No	PV1+, PV2+ and PV- abnormally low impedance to ground.
[57]	Leakage current overload fault	Yes	System leakage current exceeds limit.
[58]	BMS communication error	No	BMS communication fault.
[60]	BMS battery low temperature alarm	No	BMS low-temperature alarm (takes effect after successful BMS communication).
[61]	BMS battery over temperature alarm	No	BMS over-temperature alarm (takes effect after successful BMS communication).
[62]	BMS battery over current alarm	No	BMS over-current alarm (takes effect after successful BMS communication).
[63]	BMS battery undervoltage alarm	No	BMS under-voltage alarm (takes effect after successful BMS communication).

7.2 Troubleshooting

Fault Code	Meaning	Causes	Remedy
/	No screen display	No power input, or the switch on the bottom of the unit is not switched on.	Check whether the battery air circuit breaker or PV air circuit breaker is closed. Check if the switch is in the "ON" position. Press any button on the screen to exit the screen sleep mode.
01	Battery under-voltage	The battery voltage is lower than the value set in parameter [14].	Charge the battery until the battery voltage exceeds the set value in parameter [14].
03	Battery not connected	The battery is not connected, or the BMS is in discharge protection state.	Check whether the battery is reliably connected. Check if the battery circuit breaker is closed. Ensure that the BMS can communicate normally.
04	Battery over-discharge	The battery voltage is lower than the value set in parameter [12].	Manual reset: Turn off and restart the device. Automatic reset: Charge the battery to make the battery voltage higher than the value set in parameter [35].
06	Battery over-voltage when charging	Battery is in over-voltage condition.	Manually turn off the power and restart. Check if the battery voltage exceeds the limit value. If it does, the battery needs to be discharged until the voltage is lower than the battery overvoltage recovery point.
13	Bypass over-load (software detection)	Bypass output power or output current over-load for a period of time.	Reduce the load power and restart the device. For details, please refer to item 11 of the protection functions.
14	Inverter over-load (software detection)	Inverter output power or output current over-load for a period of time.	
19	Heat sink of PV input over-temperature (software detection)	Heat sink of PV input temperature exceeds 90°C for 3s.	Normal charging and discharging will resume when the temperature of the radiator cools down below the over-temperature recovery temperature.
20	Heat sink of inverter output over-temperature (software detection)	Heat sink of inverter output temperature exceeds 90°C for 3s.	
21	Fan failure	Hardware detects fan failure.	After turning off the machine's power, manually switch the fan and check for any foreign objects blocking it.
26	AC input relay short-circuit	The relay is used to control the AC input.	Manually shut down and restart the machine. If the fault reappears after restarting, contact the after-sales service department to repair the machine.
28	Utility input phase fault	AC input phase does not match AC output phase.	Ensure that the AC input phase is the same as the AC output phase.

NOTICE

If you encounter product faults that cannot be solved by the methods in the above table, please contact our after-sales service department for technical support and do not disassemble the equipment by yourself.

8. Protection and Maintenance

8.1 Protection Functions

No.	Protection Functions	Definition
1	PV input current / power limiting protection	When the configured PV array charging current or power exceeds the rated PV input value, the inverter will limit the input power and charge at the rated value.
2	PV overvoltage protection	If the PV voltage exceeds the maximum value allowed by the hardware, the device will report a fault and stop PV boosting to output a sinusoidal AC waveform.
3	Night anti-reverse charging protection	At night, the battery will be prevented from discharging to the PV module because the battery voltage is greater than the PV module voltage.
4	Mains input overvoltage protection	When the grid voltage of per phase exceeds 280Vac, the mains charging will be stopped and will switch to inverter output.
5	Mains input undervoltage protection	When the mains voltage of per phase falls below 170Vac, the mains charging will be stopped and will switch to inverter output.
6	Battery overvoltage protection	When the battery voltage reaches the over-voltage disconnection voltage point, it will automatically stop the PV and grid charging of the battery to prevent over-charging and damage to the battery.
7	Battery undervoltage protection	When the battery voltage reaches the low-voltage disconnection voltage point, it will automatically stop discharging the battery to prevent the battery from being over-discharged and damaged.
8	Battery overcurrent protection	When the battery current exceeds the range allowed by hardware, the machine will turn off output and stop discharging the battery.
9	AC output short-circuit protection	In the event of a load short-circuit fault, the AC output voltage will be shut down immediately. To resume normal output, the load short-circuit fault must first be eliminated, followed by a manual re-powering.
10	Radiator over-temperature protection	When the internal temperature of the inverter is too high, the inverter will stop charging and discharging; when the temperature returns to normal, the inverter will resume charging and discharging.

11	Inverter overload protection	After triggering the overload protection, the inverter will resume output after 3 minutes, 5 consecutive overloads will switch off the output until the inverter restarts. (102%<load<110%) : error, output switched off after 5 minutes. (110%<load<125%) : error reported and output switched off after 10s. (>125% load): error reported and output switched off after 5s.
12	AC backfeed protection	Prevents backfeeding of battery inverter AC to bypass AC inputs.
13	Bypass overcurrent protection	Built-in AC input overcurrent protection circuit breaker.
14	Bypass wiring error protection	When the phase of the two bypass inputs is different from the phase of the inverter phase split, the machine will prohibit cutting into the bypass to prevent the load from dropping out or short-circuiting when cutting into the bypass.

8.2 Maintenance

To maintain optimal long-term performance, it is recommended to perform the following inspections twice a year for inverter systems:

- 1.Ensure that the airflow around the inverter is not blocked and remove any dirt or debris from the radiator.
- 2.Check that all exposed conductors are not damaged by sunlight, friction with other surrounding objects, dry rot, insect or rodent damage, etc. The conductors need to be repaired or replaced if necessary.
- 3.Verify that the indications and displays are consistent with the operation of the equipment, note any faults or incorrect displays and take corrective action if necessary.
- 4.Check all terminals for signs of corrosion, insulation damage, high temperatures or burning/discolouration and tighten terminal screws.
- 5.Check for dirt, nesting insects and corrosion, clean as required, clean insect screens regularly.
- 6.If the lightning arrester has failed, replace the failed arrester in time to prevent lightning damage to the inverter or other equipment of the user.

 **DANGER**

Make sure that the inverter is disconnected from all power sources and that the capacitors are fully discharged before carrying out any checks or operations to avoid the risk of electric shock.

The Company shall not be liable for damage caused by :

1. Damage caused by improper use or use in a wrong location.
2. PV modules with an open-circuit voltage exceeding the maximum permissible voltage.
3. Damage caused by the operating temperature exceeding the restricted operating temperature range.
4. Dismantling and repair of the inverter by unauthorised persons.
5. Damage caused by force majeure: damage during transport or handling of the inverter.

9. Datasheet

MODEL	ASP48160SH3	ASP48180SH3	ASP48200SH3	Setting
INVERTER OUTPUT				
Rated Output Power	16000W	18000W	20000W	
Max. AC Output Power	17600VA	19800VA	22000VA	
Rated AC Output Current	23.2A	26.0A	29.0A	
Rated Output Frequency	50/60Hz			√
Rated Output Voltage	230/400Vac (Three-Phase)			
Output Voltage Range	230/400Vac ± 5%			
BATTERY INPUT				
Battery Types	Li-ion / Lead-Acid / User Defined			√
Rated Battery Voltage	48Vdc			
Battery Voltage Range	40-60Vdc			
Max. PV Charging Current	300A	360A	360A	√
Max. Grid/Generator Charging Current	300A	360A	360A	√
Max. Charging/Discharging Current	300A	360A	360A	√
Charging Curve	3 Stages / Equalization			
Charging Strategy for Li-Ion Battery	Self-adaption to BMS			
PV INPUT				
No. of MPPT Trackers	2			
Max. PV Input Power	15kW+15kW	15kW+15kW	15kW+15kW	
Input Current	36A+36A	36A+36A	36A+36A	
Min. PV Input Voltage / Start-up Voltage	160V/160V			

Max. PV Input Voltage	1000V/1000V	
MPPT Operating Voltage Range	160-800V/160-800V	
GRID / GENERATOR INPUT		
Rated Input Frequency	50/60Hz	
Rated Input Voltage	230/400Vac (Three-Phase)	
AC Voltage Range	Phase Voltage 170~280Vac; Line Voltage 305~485Vac	
Bypass Overload phase Current	60A	
EFFICIENCY		
MPPT Tracking Efficiency	>99.9%	
Max. Efficiency	97.6%	
GENERAL DATA		
Parallel Capacity	1~6 units	
Dimensions (W × H × D)	593.4x803.4x215mm	
Weight	50kg	
Protection Degree	IP20, indoor use only	
Operating Temperature	-10~55°C, >45°C Derating	
Noise	<60dB	
Cooling Method	Air Cooling	
COMMUNICATION		
Internal Interface	RS485 / CAN / WiFi	√
External Module (optional)	Wi-Fi/4G Stick	√
PROTECTION		
<p>With PV input current / power limiting protection, PV input over-voltage, Anti-reverse charge protection at night, AC input over-voltage protection, AC input under-voltage protection, Battery over-voltage protection, Battery under-voltage protection, Battery over-current protection, AC output short-circuit protection, Heat sink over-temperature protection, inverter over-load protection, AC output reverse, Bypass over-current protection, Bypass phase inconsistency protection.</p>		
CERTIFICATION		
Safety	IEC62109-1, IEC62109-2	
EMC	EN61000-6-1, EN61000-6-3	

SRNE Solar Co.,Ltd

Mail service@szshuori.com

Web www.srnesolar.com

Address 4-5F,Building13A,Taihua Wutong
Industrial Park ,Gushu Development
Zone , Hangcheng Street,Baoan,
Shenzhen, China PR
